



YASKAWA AC Drive-A1000

High Performance Vector Control Drive

Manual Supplement

Supplement to: A1000 Quick Start Guide TOEPC71061641C <2>

Type: CIMR-AU□A

Models: 200 V Class: 0.4 to 110 kW (3/4 to 175 HP ND)
400 V Class: 0.4 to 630 kW (3/4 to 1000 HP ND)
600 V Class: 0.75 to 185 kW (1 to 250 HP ND)

YASKAWA AC Drive P1000

Industrial Fan and Pump Drive

Manual Supplement

Supplement to: P1000 Quick Start Guide TOEYAIP1U01A

Type: CIMR-PU□A

Models: 200 V Class: 3/4 to 175 HP ND
400 V Class: 3/4 to 500 HP ND
600 V Class: 2 to 250 HP ND

To properly use the product, read this supplement thoroughly and retain for easy reference, inspection, and maintenance. Ensure the end user receives this supplement.



1 Supplemental Information - Applicable Documents

◆ Document Applicability

The contents of this supplement replace or add to the contents of the product manual sections listed in [Table 1](#).

Table 1 Affected Documents and Sections

Yaskawa Product	Document	Chapter	Section
AC Drive - A1000	Quick Start Guide No. TOEP C710616 41C <2> and prior	Preface & General Safety	Safety Messages (revised)
		Chapter 1 - Receiving	Nameplate (revised)
		Chapter 2 - Mechanical Installation	Installation Environment (revised), Dimensions (added))
		Appendix A - Specifications	A.5 Drive Derating Data (added)
		Appendix C - Standards Compliance	UL and CSA Standards (revised)
	Technical Manual No. SIEP C710616 41C <2> and prior	Preface & General Safety	Safety Messages (revised)
		Chapter 1 - Receiving	Nameplate (revised)
		Chapter 2 - Mechanical Installation	Installation Environment (revised), Dimensions (added)
		Appendix A - Specifications	A.5 Drive Derating Data (revised)
		Appendix D - Standards Compliance	UL and CSA Standards (revised)
AC Drive - P1000	Quick Start Guide No. TOEP YAIP1U 01A	Preface & General Safety	Safety Messages (revised)
		Chapter 1 - Receiving	Nameplate (revised)
		Chapter 2 - Mechanical Installation	Installation Environment (revised), Dimensions (added))
		Appendix A - Specifications	A.5 Drive Derating Data (added)
		Appendix C - Standards Compliance	UL and CSA Standards (revised)
	Technical Manual No. SIEP YAIP1U 01A	Preface & General Safety	Safety Messages (revised)
		Chapter 1 - Receiving	Nameplate (revised)
		Chapter 2 - Mechanical Installation	Installation Environment (revised), Dimensions (added)
		Appendix A - Specifications	A.5 Drive Derating Data (revised)
		Appendix D - Standards Compliance	UL and CSA Standards (revised)

2 Supplemental Information - Preface - Safety Messages

WARNING

Fire Hazard - Drive Short-Circuit Current Rating

Install adequate branch circuit protection according to applicable local codes and this Installation Manual. Failure to comply could result in fire and damage to the drive or injury to personnel.

The device is suitable for use on a circuit capable of delivering not more than 100,000 RMS symmetrical amperes, 240 Vac maximum (200 V class) and 480 Vac maximum (400 V class), and 600 Vac maximum (600 V class) when protected by branch circuit protection devices specified in this supplement.

3 Supplemental Information - Receiving - Applicable Models

The A1000 and P1000 models listed in *Table 2* are affected by this supplement.

Table 2 Applicable A1000 and P1000 Models

Voltage Class	Model Number CIMR-□U□ A		
200 V	2A0004 2A0006 2A0008 2A0010 2A0012 2A0018 2A0021	2A0030 2A0040 2A0056 2A0069 2A0081 2A0110 2A0138	2A0169 2A0211 2A0250 2A0312 2A0360 2A0415
400 V	4A0002 4A0004 4A0005 4A0007 4A0009 4A0011 4A0018 4A0023 4A0031	4A0038 4A0044 4A0058 4A0072 4A0088 4A0103 4A0139 4A0165 4A0208	4A0250 4A0296 4A0362 4A0414 4A0515 4A0675 4A0930 <I> 4A1200 <I>
600 V	5A0003 5A0004 5A0006 5A0009 5A0011 5A0017	5A0022 5A0027 5A0032 5A0041 5A0052 5A0062	5A0077 5A0099 5A0125 5A0145 5A0192 5A0242

<I> Not available in P1000 series.

4 Supplemental Information - UL and CSA Standards

◆ UL and CSA Standards Compliance

The UL/cUL mark applies to products in the United States and Canada. It indicates that UL has performed product testing and evaluation, and determined that their stringent standards for product safety have been met. For a product to receive UL certification, all components inside that product must also receive UL certification.



Figure 1 UL/cUL Mark

This drive is tested in accordance with UL Standard for Safety UL508C and complies with UL requirements. The conditions described below must be met to maintain compliance when using this drive in combination with other equipment.

◆ A1000 & P1000 Factory Recommended Branch Circuit Protection

Yaskawa recommends installing one of the following types of branch circuit protection to maintain compliance with UL508C. Semiconductor protective type fuses are preferred. Alternate branch circuit protection devices are also listed in [Table 3](#).

Table 3 A1000 & P1000 Factory Recommended AC Drive Branch Circuit Protection

Drive Model	A1000 and P1000 in Normal Duty Mode (Parameter C6-01 =1 <6>)						A1000 in Heavy Duty Mode <7> (Parameter C6-01 =0)					
	Nominal Output Power HP	AC Drive Input Amps	MCCB Rating Amps <1>	Time Delay Fuse Rating Amps <2>	Non-time Delay Fuse Rating Amps <3>	Bussman Semi-conductor Fuse Rating (Fuse Ampere) <4>	Nominal Output Power HP	AC Drive Input Amps	MCCB Rating Amps <1>	Time Delay Fuse Rating Amps <2>	Non-time Delay Fuse Rating Amps <3>	Bussman Semi-conductor Fuse Rating (Fuse Ampere) <4>
240 V Models												
2□0004	0.75	3.9	15	6.25	10	FWH-70B (70)	0.75	2.9	15	5	8	FWH-70B (70)
2□0006	1 - 1.5	7.3	15	12	20	FWH-70B (70)	1	5.8	15	10	15	FWH-70B (70)
2□0008	2	8.8	15	15	25	FWH-70B (70)	2	7	15	12	17.5	FWH-70B (70)
2□0010	3	10.8	20	17.5	30	FWH-70B (70)	2	7.5	15	12	20	FWH-70B (70)
2□0012	3	13.9	25	20	40	FWH-70B (70)	3	11	20	17.5	30	FWH-70B (70)
2□0018	5	18.5	35	30	50	FWH-90B(90)	3	15.6	25	25	40	FWH-90B(90)
2□0021	7.5	24	45	40	70	FWH-90B(90)	5	18.9	35	30	50	FWH-90B(90)
2□0030	10	37	60	60	110	FWH-100B (100)	7.5	28	50	40	75	FWH-100B (100)
2□0040	15	52	100	90	150	FWH-200B (200)	10	37	60	60	100	FWH-200B (200)
2□0056	20	68	125	110	200	FWH-200B (200)	15	52	100	90	150	FWH-200B (200)
2□0069	25	80	150	125	225	FWH-200B (200)	20	68	125	110	200	FWH-200B (200)
2□0081	30	96	175	150	275	FWH-300A (300)	25	80	150	125	225	FWH-300A (300)
2□0110	40	111	200	175	300	FWH-300A (300)	30	82	150	125	225	FWH-300A (300)
2□0138	50	136	250	225	400	FWH-350A (350)	40	111	200	175	250	FWH-350A (350)
2□0169	60	164	300	250	450	FWH-400A (400)	50	136	250	225	350	FWH-400A (400)
2□0211	75	200	400	350	600	FWH-400A (400)	60	164	300	250	450	FWH-400A (400)
2□0250	100	271	500	450	800	FWH-600A (600)	75	200	400	350	600	FWH-600A (600)
2□0312	125	324	600	500	800	FWH-700A (700)	100	271	500	450	800	FWH-700A (700)
2□0360	150	394	700	600	1000 <5>	FWH-800A (800)	125	324	600	500	900 <5>	FWH-800A (800)
2□0415	175	471	900	800	1400 <5>	FWH-1000A (1000)	150	394	700	600	1100 <5>	FWH-1000A (1000)

4 Supplemental Information - UL and CSA Standards

Drive Model	A1000 and P1000 in Normal Duty Mode (Parameter C6-01 =1 <6>)						A1000 in Heavy Duty Mode <7> (Parameter C6-01 =0)					
	Nominal Output Power HP	AC Drive Input Amps	MCCB Rating Amps <1>	Time Delay Fuse Rating Amps <2>	Non-time Delay Fuse Rating Amps <3>	Bussman Semi-conductor Fuse Rating (Fuse Ampere) <4>	Nominal Output Power HP	AC Drive Input Amps	MCCB Rating Amps <1>	Time Delay Fuse Rating Amps <2>	Non-time Delay Fuse Rating Amps <3>	Bussman Semi-conductor Fuse Rating (Fuse Ampere) <4>
480 V Models												
4□0002	1	2.1	15	3.5	6	FWH-40B (40)	0.75	1.8	15	3	5	FWH-40B (40)
4□0004	2	4.3	15	7.5	12	FWH-50B (50)	1 - 2	3.2	15	5	9	FWH-50B (50)
4□0005	3	5.9	15	10	17.5	FWH-70B (70)	3	4.4	15	7	12	FWH-70B (70)
4□0007	3	8.1	15	12	20	FWH-70B (70)	3	6	15	10	17.5	FWH-70B (70)
4□0009	5	9.4	15	15	25	FWH-90B (90)	5	8.2	15	12	20	FWH-90B (90)
4□0011	7.5	14	25	20	40	FWH-90B (90)	5	10.4	20	17.5	30	FWH-90B (90)
4□0018	10	20	40	35	60	FWH-80B (80)	7.5 - 10	15	30	25	40	FWH-80B (80)
4□0023	15	24	45	40	70	FWH-100B (100)	10	20	40	35	60	FWH-100B (100)
4□0031	20	38	75	60	110	FWH-125B (125)	15	29	50	50	80	FWH-125B (125)
4□0038	25	44	75	75	125	FWH-200B (200)	20	39	75	60	110	FWH-200B (200)
4□0044	30	52	100	90	150	FWH-250A (250)	25 - 30	47	75	75	125	FWH-250A (250)
4□0058	40	58	100	100	150	FWH-250A (250)	30	43	75	75	125	FWH-250A (250)
4□0072	50	71	125	110	200	FWH-250A (250)	40	58	100	100	150	FWH-250A (250)
4□0088	60	86	150	150	250	FWH-250A (250)	60	71	125	110	200	FWH-250A (250)
4□0103	75	105	200	175	300	FWH-250A (250)	60	86	150	150	250	FWH-250A (250)
4□0139	100	142	250	225	400	FWH-350A (350)	75	105	175	175	300	FWH-350A (350)
4□0165	125	170	300	250	500	FWH-400A (400)	100	142	225	225	400	FWH-400A (400)
4□0208	150	207	400	350	600	FWH-500A (500)	125 - 150	170	250	250	500	FWH-500A (500)
4□0250	200	248	450	400	700	FWH-600A (600)	150	207	350	350	600	FWH-600A (600)
4□0296	250	300	600	500	800	FWH-700A (700)	200	248	400	400	700	FWH-700A (700)
4□0362	300	346	600	600	1000 <5>	FWH-800A (800)	250	300	500	500	800	FWH-800A (800)
4□0414	350	410	800	700	1200 <5>	FWH-800A (800)	300	346	600	600	1000 <5>	FWH-800A (800)
4□0515	400 - 450	465	900	800	1350 <5>	FWH-1000A (1000)	350	410	700	700	1200 <5>	FWH-1000A (1000)
4□0675	500 - 600	657	1200	1100 <5>	1800 <5>	FWH-1200A (1200)	400 - 500	584	1000	1000 <5>	1600 <5>	FWH-1200A (1200)
4□0930 <8>	700 - 800	922	Not Applicable			FWH-1200A (1200)	600 - 700	830	Not Applicable			FWH-1200A (1200)
4□1200 <8>	900 - 1000	1158	Not Applicable			FWH-1600A (1600)	800 - 900	1031	Not Applicable			FWH-1600A (1600)
600 V Models												
5□0003	2	3.6	15	6.25	10	FWP-50B (50)	1	1.9	15	3	5	FWP-50B (50)
5□0004	3	5.1	15	8	15	FWP-50B (50)	2	3.6	15	6.25	10	FWP-50B (50)
5□0006	5	8.3	15	12	20	FWP-60B (60)	3	5.1	15	8	15	FWP-60B (60)
5□0009	7.5	12	20	20	35	FWP-60B (60)	5	8.3	15	12	20	FWP-60B (60)
5□0011	10	16	30	25	45	FWP-70B (70)	7.5	12	20	20	35	FWP-70B (70)
5□0017	15	23	40	40	60	FWP-100B (100)	10	16	30	25	45	FWP-100B (100)
5□0022	20	31	60	50	90	FWP-100B (100)	15	23	40	40	60	FWP-100B (100)
5□0027	25	38	75	60	110	FWP-125A (125)	20	31	60	50	90	FWP-125A (125)
5□0032	30	45	75	75	125	FWP-125A (125)	25	38	75	60	100	FWP-125A (125)
5□0041	40	44	75	75	125	FWP-175A (175)	30	33	60	50	90	FWP-175A (175)
5□0052	50	54	100	90	150	FWP-175A (175)	40	44	75	75	125	FWP-175A (175)
5□0062	60	66	125	110	175	FWP-250A (250)	50	54	100	90	150	FWP-250A (250)
5□0077	75	80	150	125	225	FWP-250A (250)	60	66	125	110	175	FWP-250A (250)
5□0099	100	108	175	175	300	FWP-250A (250)	75	80	150	125	225	FWP-250A (250)
5□0125	125	129	225	225	350	FWP-350A (350)	100	108	175	175	300	FWP-350A (350)
5□0145	150	158	300	275	450	FWP-350A (350)	125	129	250	225	350	FWP-350A (350)
5□0192	200	228	400	350	600	FWP-600A (600)	150	158	300	250	400	FWP-600A (600)
5□0242	250	263	500	450	700	FWP-600A (600)	200	228	400	350	600	FWP-600A (600)

- <1> Maximum MCCB Rating is 15 A, or 200 % of drive input current rating, whichever is larger. MCCB voltage rating must be 600 VAC or greater.
- <2> Maximum Time Delay fuse is 175% of drive input current rating. This covers any Class CC, J or T class fuse.
- <3> Maximum Non-time Delay fuse is 300% of drive input current rating. This covers any CC, J or T class fuse.
- <4> When using semiconductor fuses, Bussman FWH and FWP are required for UL compliance. Select FWH for 240 V and 480 V models and FWP fuses for 600 V models.
- <5> Class L fuse is also approved for this rating.
- <6> Duty Rating parameter C6-01 is only available for A1000 series drives.
- <7> Heavy Duty rating and parameter C6-01 is not available for P1000 series drives.
- <8> Not available in P1000 series.

5 Supplemental Information - Specifications - Drive Derating

◆ A1000 & P1000 Single-Phase Derating

A1000 and P1000 drives are optimized and compatible for use with both three-phase and single-phase input power supplies. The output to the motor is fixed at three-phase.

Output capacity to the motor is reduced or derated when single-phase input power is used.

Selection of larger models always results in greater output capacity to the motor when the drive supplied with three-phase input power. Conversely, selection of larger models does not always yield greater output capacity when the drive used with single-phase input power.

Several factors affect the amount of derated drive output capacity when single-phase input power is supplied to the drive, such as:

- single-phase input voltage level
- motor voltage rating
- amount of input impedance

The tables in this section assist in model selection by considering factors that affect the amount of derating in single-phase input power applications.

The Output Capacity-Motor FLA listed in the tables allows for a 120% overload for 60 seconds.

Contact Yaskawa if assistance is needed in selecting drive models for heavy duty/single-phase applications with higher overload requirements.

Table 4 240 V Single Phase Input (-5% to +10%), 230 V Three Phase Motor

Drive Model	Without Additional Impedance				With Additional Impedance (use either DC type or AC type)					
	Output Capacity		Single Phase Input Load		Yaskawa Reactor Part Number		Output Capacity		Single Phase Input Load	
	Motor Power (HP)	Motor FLA	Power (kVA)	Current (A)	DC Type	AC Type	Motor Power (HP)	Motor FLA	Power (kVA)	Current (A)
2A0004	0.33	1.52	0.99	4.3	URX000043	URX000303	0.5	2.2	0.94	4.1
2A0006	0.5	2.2	1.3	5.7	URX000043	URX000303	0.75	3.2	1.3	5.7
2A0008	0.75	3.2	1.7	7.7	05P00620-0113	URX000307	1	4.2	1.6	7.2
2A0010	0.75	3.2	1.8	7.7	05P00620-0113	URX000311	1	4.2	1.8	7.8
2A0012	1	4.2	2.3	10	URX000048	URX000316	2	7.5	2.9	13
2A0018	2	6.8	4.3	19	05P00620-0120	URX000319	3	9.6	4.3	19
2A0021	2	6.8	4.3	19	05P00620-0120	URX000323	3	9.6	4.4	19
2A0030	2	6.8	4.5	20	05P00620-0120	URX000323	3	9.6	4.4	19
2A0040	3	9.6	6.2	27	05P00620-0124	URX000323	5	15.2	6.7	30
2A0056	5	15.2	9.9	43	URX000059	URX000326	7.5	22	9.6	42
2A0069	5	15.2	10	45	URX000063	URX000332	10	28	13	56
2A0081	10	28	18	79	URX000072	URX000338	15	42	19	84
2A0110	10	28	14	60	DC Reactor Built-in	Do Not Use AC Reactor	10	28	14	60
2A0138	15	42	20	87			15	42	20	87
2A0169	20	54	26	114			20	54	26	114
2A0211	20	54	26	116			20	54	26	116
2A0250	25	68	32	143			25	68	32	143
2A0312	30	80	39	170			30	80	39	170
2A0360	40	104	51	224			40	104	51	224
2A0415	50	130	63	275			50	130	63	275

5 Supplemental Information - Specifications - Drive Derating

Table 5 240 V Single-Phase Input (-5% to +10%), 208 V Three-Phase Motor

Drive Model	Without Additional Impedance				With Additional Impedance (use either DC type or AC type)					
	Output Capacity		Single Phase Input Load		Yaskawa Reactor Part Number		Output Capacity		Single Phase Input Load	
	Motor Power (HP)	Motor FLA	Power (kVA)	Current (A)	DC Type	AC Type	Motor Power (HP)	Motor FLA	Power (kVA)	Current (A)
2A0004	0.33	1.7	0.99	4.3	URX000043	URX000303	0.5	2.4	0.94	4.1
2A0006	0.5	2.4	1.3	5.7	URX000043	URX000303	0.75	3.5	1.3	5.7
2A0008	0.75	3.5	1.7	7.7	05P00620-0113	URX000307	1	4.6	1.6	7.2
2A0010	0.75	3.5	1.8	7.7	05P00620-0113	URX000311	1	4.6	1.8	7.8
2A0012	1	4.6	2.3	10	05P00620-0115	URX000315	2	7.5	2.9	13
2A0018	2	7.5	4.3	19	05P00620-0120	URX000319	3	10.6	4.3	19
2A0021	2	7.5	4.3	19	05P00620-0120	URX000323	3	10.6	4.4	19
2A0030	2	7.5	4.5	20	05P00620-0120	URX000323	3	10.6	4.4	19
2A0040	3	10.6	6.2	27	05P00620-0124	URX000323	5	17	6.7	30
2A0056	5	17	9.9	43	URX000059	URX000326	7.5	24	9.6	42
2A0069	5	17	10	45	URX000063	URX000332	10	31	13	56
2A0081	10	31	18	79	URX000072	URX000339	15	46	19	84
2A0110	10	31	14	60	DC Reactor Built-in	URX000340	15	46	17	76
2A0138	15	46	20	87		URX000343	15	46	18	77
2A0169	20	59	26	114		URX000342	20	59	23	102
2A0211	20	59	26	116		URX000344	25	75	29	129
2A0250	25	75	32	143		URX000347	30	88	35	156
2A0312	30	88	39	170		URX000350	40	114	47	204
2A0360	40	114	51	224		URX000353	50	143	57	252
2A0415	50	143	63	275		URX000356	60	169	69	301

Table 6 480 V Single Phase Input (-5% to +10%), 460 V Three Phase Motor

Drive Model	Without Additional Impedance				With Additional Impedance (use either DC type or AC type)					
	Output Capacity		Single Phase Input Load		Yaskawa Reactor Part Number		Output Capacity		Single Phase Input Load	
	Motor Power (HP)	Motor FLA	Power (kVA)	Current (A)	DC Type	AC Type	Motor Power (HP)	Motor FLA	Power (kVA)	Current (A)
4A0002	0.33	0.76	1.1	2.4	URX000041	URX000295	0.5	1.1	0.98	2.1
4A0004	0.75	1.6	1.9	4.2	URX000041	URX000299	1	2.1	1.7	3.8
4A0005	1	2.1	2.3	5.1	05P00620-0110	URX000303	1.5	3	2.5	5.5
4A0007	1	2.1	2.5	5.6	05P00652-0213	URX000308	2	3.4	3	6.7
4A0009	2	3.4	4.6	10	URX000048	URX000312	3	4.8	4.3	9.5
4A0011	2	3.4	4.6	10	URX000053	URX000316	3	4.8	4.7	10
4A0018	2	3.4	4.4	9.7	URX000052	URX000316	3	4.8	4.6	10
4A0023	3	4.8	6.3	14	URX000052	URX000316	5	7.6	7	15
4A0031	5	7.6	10	22	URX000055	URX000324	7.5	11	9.9	22
4A0038	7.5	11	14	31	05P00620-0123	URX000327	10	14	14	31
4A0044	7.5	11	14	31	URX000061	URX000327	10	14	13	28
4A0058	10	14	14	30	DC Reactor Built-in	URX000332	15	21	19	41
4A0072	15	21	20	43		Do Not Use AC Reactor	15	21	20	43
4A0088	15	21	20	44		Do Not Use AC Reactor	15	21	20	44
4A0103	15	21	20	45		URX000335	20	27	25	54
4A0139	30	40	38	84		URX000341	30	40	36	80
4A0165	30	40	39	85		URX000341	30	40	37	81
4A0208	50	65	62	136		URX000347	50	65	59	130
4A0250	60	77	74	162		URX000347	60	77	70	154
4A0296	60	77	75	165		URX000350	75	96	87	192
4A0362	75	96	93	205		URX000353	100	124	115	251
4A0414	100	124	122	267		URX000356	125	156	143	314
4A0515	100	124	125	275		URX000353	100	124	116	255
4A0675	125	156	157	345	Do Not Use	125	156	157	345	

5 Supplemental Information - Specifications - Drive Derating

Table 7 480 V Single Phase Input (-5% to +10%), 400 V Three Phase Motor

Drive Model	Without Additional Impedance				With Additional Impedance (use either DC type or AC type)					
	Output Capacity		Single Phase Input Load		Yaskawa Reactor Part Number		Output Capacity		Single Phase Input Load	
	Motor Power (HP)	Motor FLA	Power (kVA)	Current (A)	DC Type	AC Type	Motor Power (HP)	Motor FLA	Power (kVA)	Current (A)
4A0002	0.33	0.88	1.1	2.4	URX000041	URX000295	0.5	1.26	0.98	2.1
4A0004	0.75	1.8	1.9	4.2	URX000041	URX000299	1	2.4	1.7	3.8
4A0005	1	2.4	2.3	5.1	05P00620-0110	URX000303	1.5	3.4	2.5	5.5
4A0007	1	2.4	2.5	5.6	05P00652-0213	URX000308	2	3.9	3	6.7
4A0009	2	3.9	4.6	10	URX000048	URX000312	3	5.5	4.3	9.5
4A0011	2	3.9	4.6	10	URX000053	URX000316	3	5.5	4.7	10
4A0018	2	3.9	4.4	9.7	URX000052	URX000316	3	5.5	4.6	10
4A0023	3	5.5	6.3	14	URX000052	URX000316	5	8.7	7	15
4A0031	5	8.7	10	22	URX000055	URX000324	7.5	12.7	9.9	22
4A0038	7.5	12.7	14	31	05P00620-0123	URX000327	10	16	14	31
4A0044	7.5	12.7	14	31	URX000061	URX000327	10	16	13	28
4A0058	10	16	14	30		URX000332	15	24	19	41
4A0072	15	24	20	43		URX000336	20	31	24	52
4A0088	15	24	20	44		URX000336	20	31	24	52
4A0103	15	24	20	45		URX000335	20	31	25	54
4A0139	30	46	38	84		URX000341	30	46	36	80
4A0165	30	46	39	85		URX000341	30	46	37	81
4A0208	50	75	62	136		URX000347	50	75	59	130
4A0250	60	89	74	162		URX000347	60	89	70	154
4A0296	60	89	75	165		URX000350	75	110	87	192
4A0362	75	110	93	205		URX000353	100	143	115	251
4A0414	100	143	122	267		URX000356	125	179	143	314
4A0515	100	143	125	275		URX000353	100	143	116	255
4A0675	125	179	157	345		URX000360	150	207	169	371
					DC Reactor Built-in					

Table 8 600 V Single Phase Input (-5% to +10%), 575 V Three Phase Motor

Drive Model	Without Additional Impedance				With Additional Impedance (use either DC type or AC type)					
	Output Capacity		Single Phase Input Load		Yaskawa Reactor Part Number		Output Capacity		Single Phase Input Load	
	Motor Power (HP)	Motor FLA	Power (kVA)	Current (A)	DC Type	AC Type	Motor Power (HP)	Motor FLA	Power (kVA)	Current (A)
5A0003	1	1.7	2	3.5	05P00620-0110	URX000303	1.5	2.4	2.6	4.6
5A0004	1.5	2.4	2.7	4.8	URX000044	URX000306	2	2.7	2.9	5
5A0006	2	2.7	4	7	05P00652-0213	URX000308	3	3.9	4.3	7.6
5A0009	3	3.9	5.4	9.5	URX000049	URX000313	5	6.1	6.5	11
5A0011	2	2.7	4.1	7.1	05P00652-0213	URX000308	3	3.9	4.4	7.7
5A0017	5	6.1	9.1	16	URX000048	URX000316	5	6.1	7.1	12
5A0022	5	6.1	9.2	16	URX000053	URX000320	7.5	9	10	18
5A0027	7.5	9	14	24	URX000055	URX000324	10	11	13	23
5A0032	7.5	9	14	24	URX000055	URX000324	10	11	13	23
5A0041	10	11	14	24		URX000326	15	17	18	32
5A0052	15	17	19	34		URX000326	15	17	19	32
5A0062	20	22	27	47		URX000335	25	27	31	54
5A0077	25	27	32	57		URX000338	30	32	36	64
5A0099	30	32	38	66		URX000338	30	32	37	64
5A0125	40	41	49	86		URX000344	50	52	58	102
5A0145	40	41	49	86		URX000344	50	52	58	102
5A0192	60	62	74	130		URX000347	75	77	87	152
5A0242	75	77	91	159		URX000347	75	77	87	152
					DC Reactor Built-in					

6 Supplemental Information - Flange Type Enclosure

Flange Type Enclosure models for A1000 and P1000 have the same specifications as standard models except for the mechanical data provided in this supplement section. Refer to the Quick Start Guide or Technical Manual of your drive for all other technical specifications and product instructions.

◆ Model Number and Nameplate Check - A1000 & P1000 Flange Type Enclosure (NEMA 12 Backside)

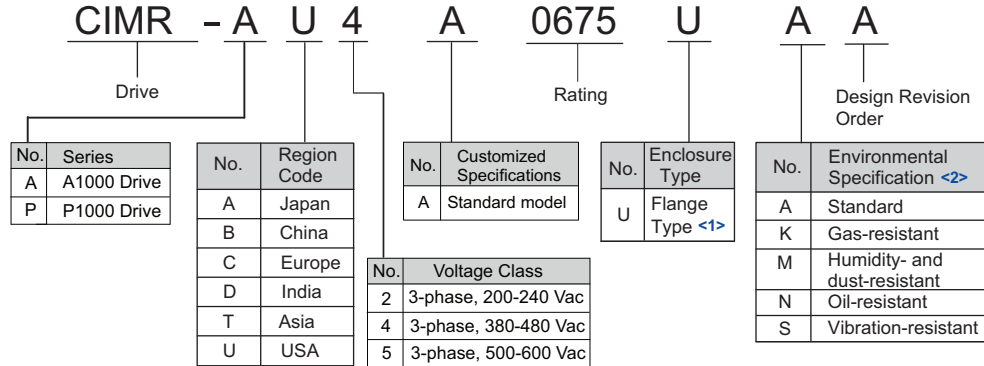

<1> Provides method of mounting drive with backside (heatsink) external to enclosure, with NEMA 12 integrity.
 <2> Drives with these specifications do not guarantee complete protection for the environmental conditions indicated.

◆ Enclosure Components - A1000 & P1000 Flange Type Enclosure (NEMA 12 Backside)

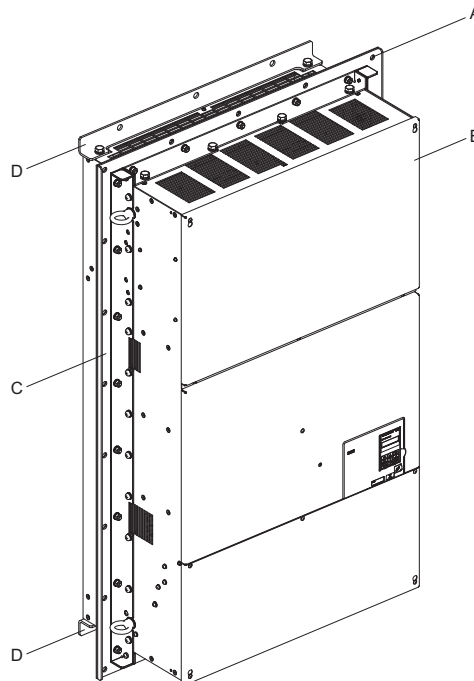

- A – Installation hole**
- B – Flange Type Drive (NEMA 12 Backside)**
- C – Mounting flange <1>**
- D – Shipping package attachment (remove before installation)**

<1> Provides method of mounting drive with backside (heatsink) external to enclosure, with NEMA 12 integrity.

Figure 2 Flange Type Enclosure (Model 4A0675U)

NOTICE: Remove the shipping package attachments before installing.

◆ Installation Environment - A1000 & P1000 Flange Type Enclosure (NEMA 12 Backside)

Table 9 A1000 & P1000 Flange Type Enclosure Installation Environment

Environment	Conditions
Installation Area	Indoors
Ambient Temperature	-10°C to +40°C (Flange Type Enclosure) Drive reliability improves in environments without wide temperature fluctuations. When using the drive in an enclosure panel, install a cooling fan or air conditioner in the area to ensure that the air temperature inside the enclosure does not exceed the specified levels. Do not allow ice to develop on the drive.
Humidity	95% RH or less and free of condensation
Storage Temperature	-20°C to +60°C
Surrounding Area	Install the drive in an area free from: <ul style="list-style-type: none"> • oil mist and dust • metal shavings, oil, water, or other foreign materials • radioactive materials • combustible materials (e.g., wood) • harmful gases and liquids • excessive vibration • chlorides • direct sunlight.
Altitude	Up to 1000 m without derating, up to 3000 m with output current and voltage derating.
Vibration	10 Hz to 20 Hz at 9.8 m/s ² 20 Hz to 55 Hz at 5.9 m/s ² (Models 4T0058 to 0165) or 2.0 m/s ² (Models 4T0208 to 0675)
Orientation	Install the drive vertically to maintain maximum cooling effects.

◆ Removing the Shipping Package Attachments

Remove the shipping package attachments before installation.

Note: The number of screws varies in accordance with the drive model.

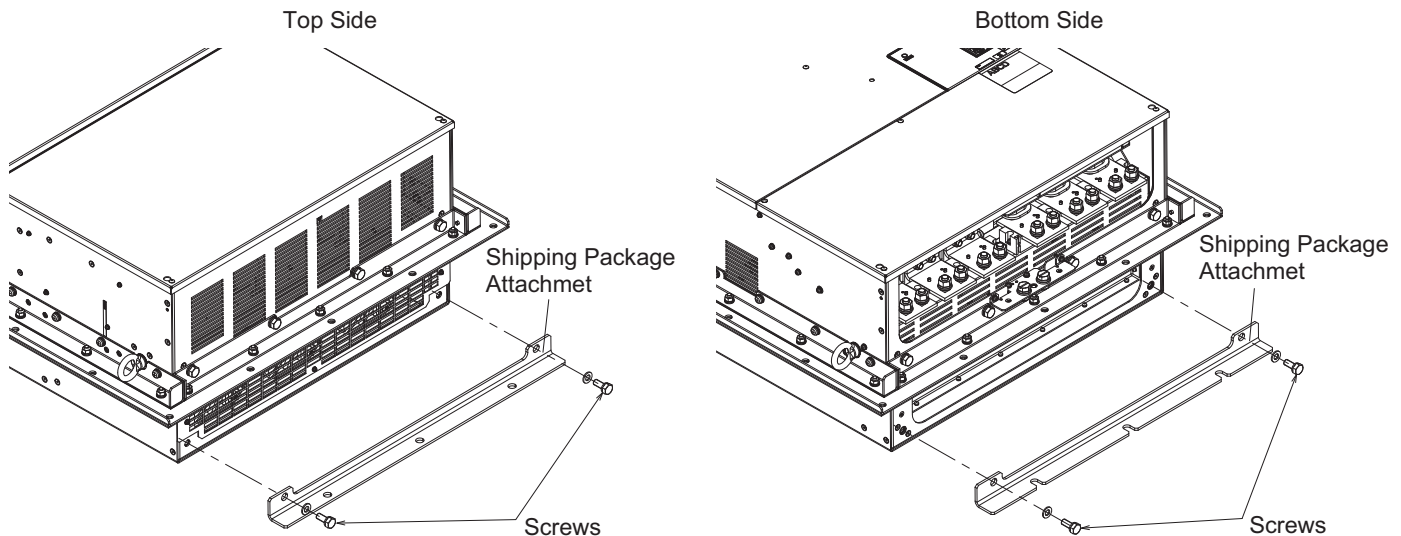

Figure 3 Removing the Shipping Package Attachments (example: Model 4A0675U)

◆ Dimensions - Flange Type Enclosure (NEMA 12 Backside)

■ A1000 & P1000 Models 2A0004U to 0012U, 4A0002U to 0005U, 5A0003U to 0004U

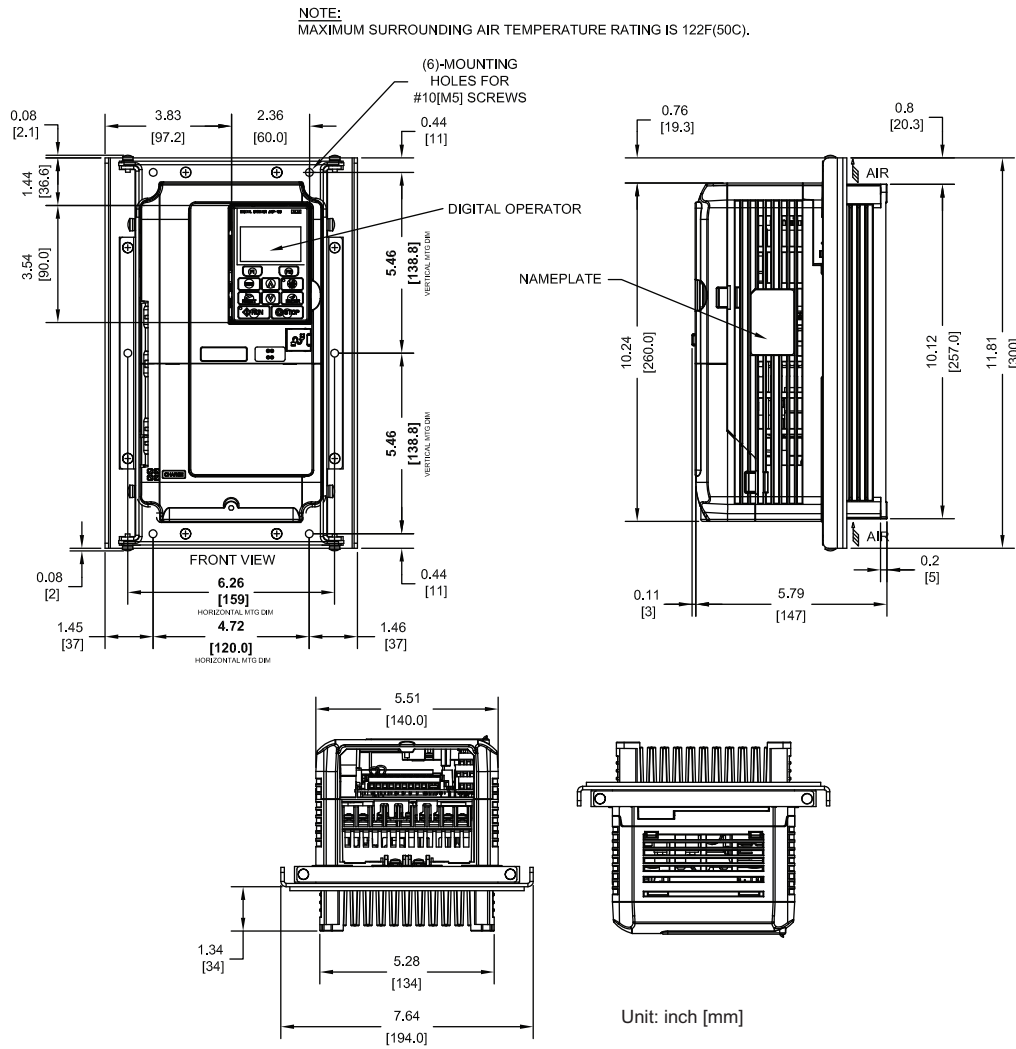

Figure 4 Dimensions (Models 2A0004U to 0012U, 4A0002U to 0005U, 5A0003U to 0004U)

6 Supplemental Information - Flange Type Enclosure

■ A1000 & P1000 Models 2A0018U to 0021U, 4A0007U to 0011U, 5A0006U to 0009U

NOTE:
MAXIMUM SURROUNDING AIR TEMPERATURE RATING IS 122F(50C).

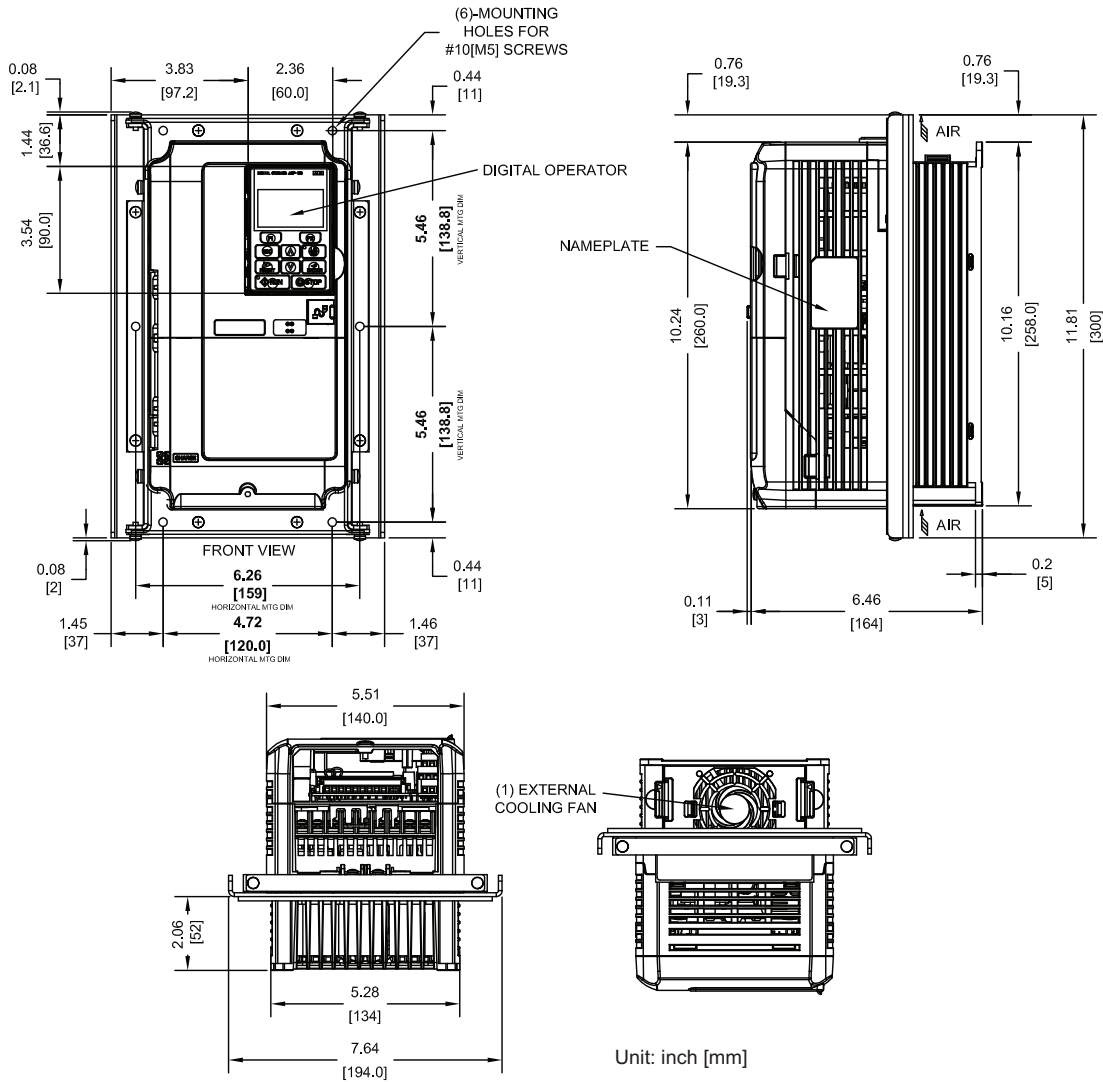

Figure 5 Dimensions (Models 2A0018U to 0021U, 4A0007U to 0011U, 5A0006U to 0009U)

■ A1000 & P1000 Models 2A0030U to 0040U, 4A0018U to 0023U, 5A0011U

NOTE:
MAXIMUM SURROUNDING AIR TEMPERATURE RATING IS 122F(50C).

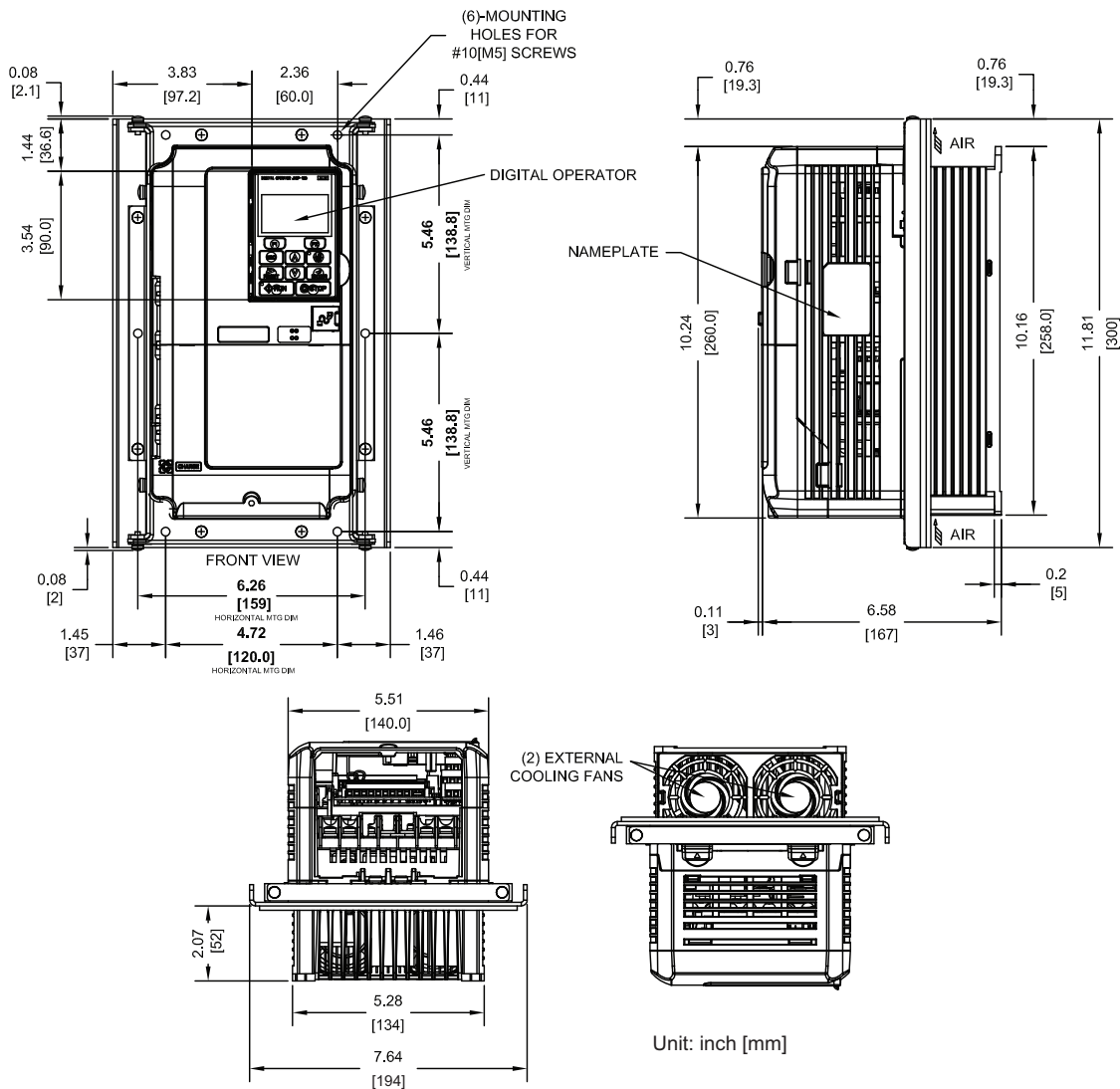

Figure 6 Dimensions (Models 2A0030U to 0040U, 4A0018U to 0023U, 5A0011U)

6 Supplemental Information - Flange Type Enclosure

■ A1000 & P1000 Model 4A0031U

NOTE:
MAXIMUM SURROUNDING AIR TEMPERATURE RATING IS 122F(50C).

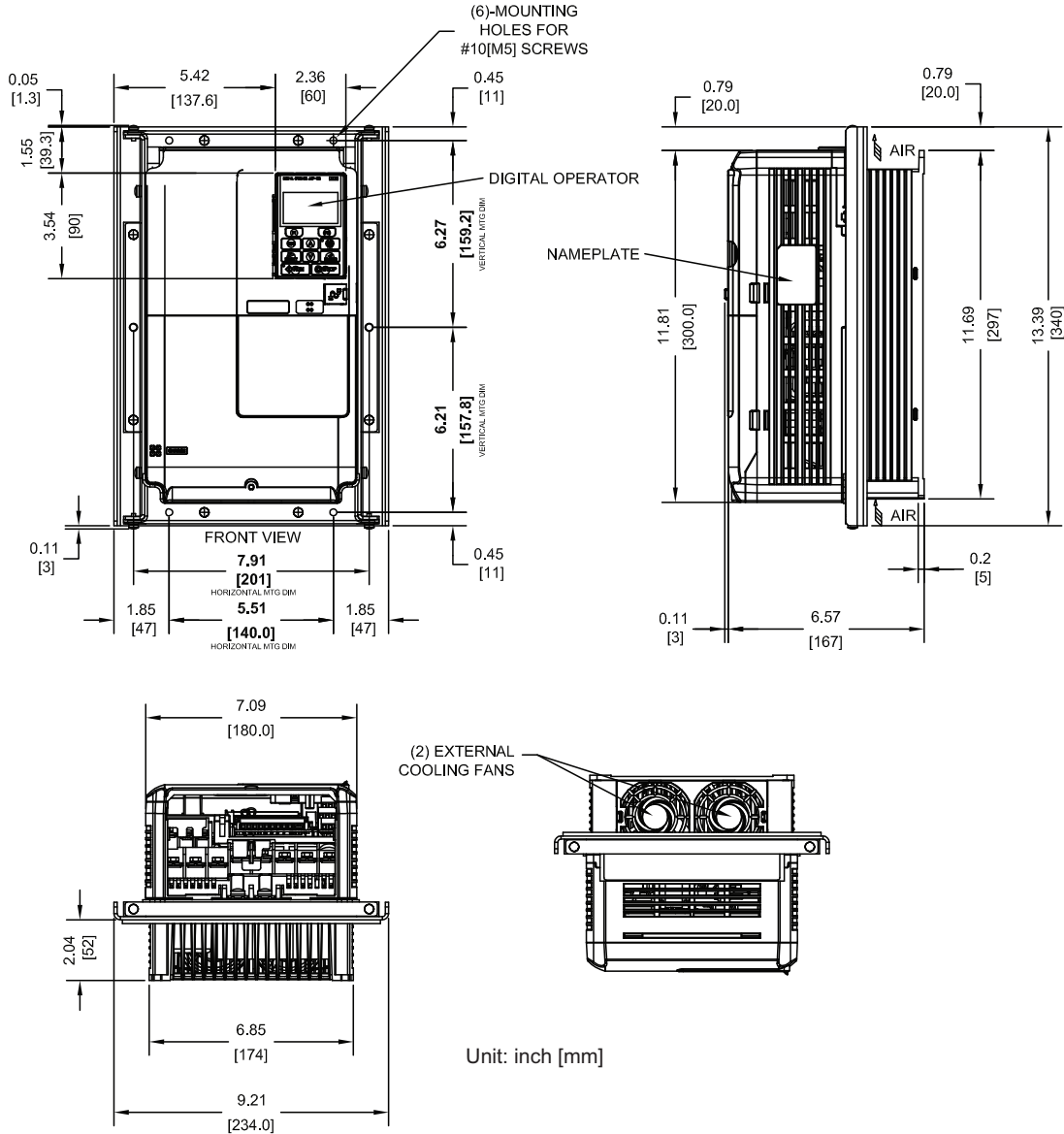

Figure 7 Dimensions (Model 4A0031U)

■ A1000 & P1000 Models 2A0056U, 4A0038U, 5A0017U, 5A0022U

NOTE:
MAXIMUM SURROUNDING AIR TEMPERATURE RATING IS 122F(50C).

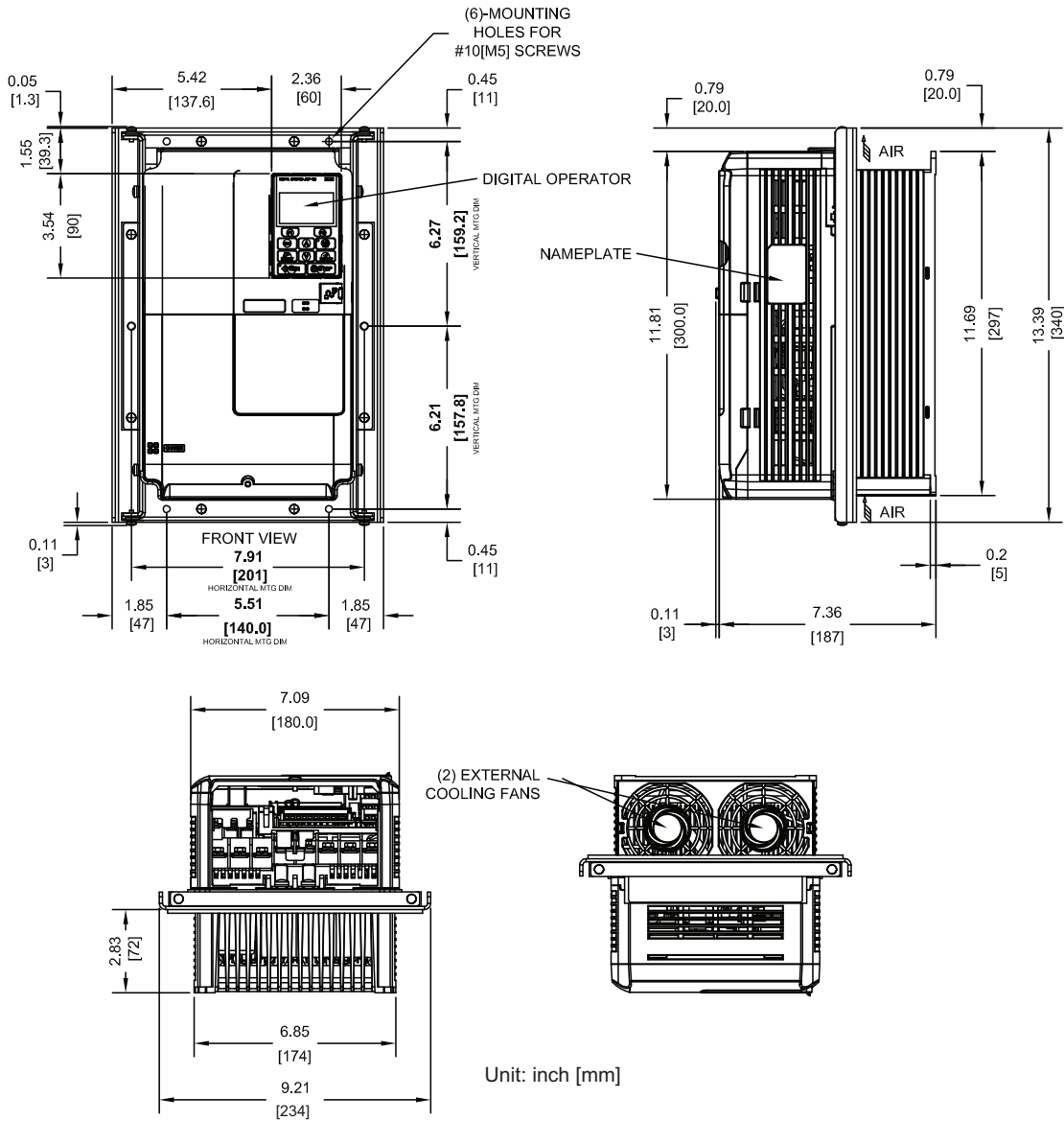

Figure 8 Dimensions (Models 2A0056U, 4A0038U, 5A0017U, 5A0022U)

6 Supplemental Information - Flange Type Enclosure

■ A1000 & P1000 Models 2A0069U, 2A0081U, 4A0044U, 5A0027U, 5A0032U

NOTE:
MAXIMUM SURROUNDING AIR TEMPERATURE RATING IS 122F(50C).

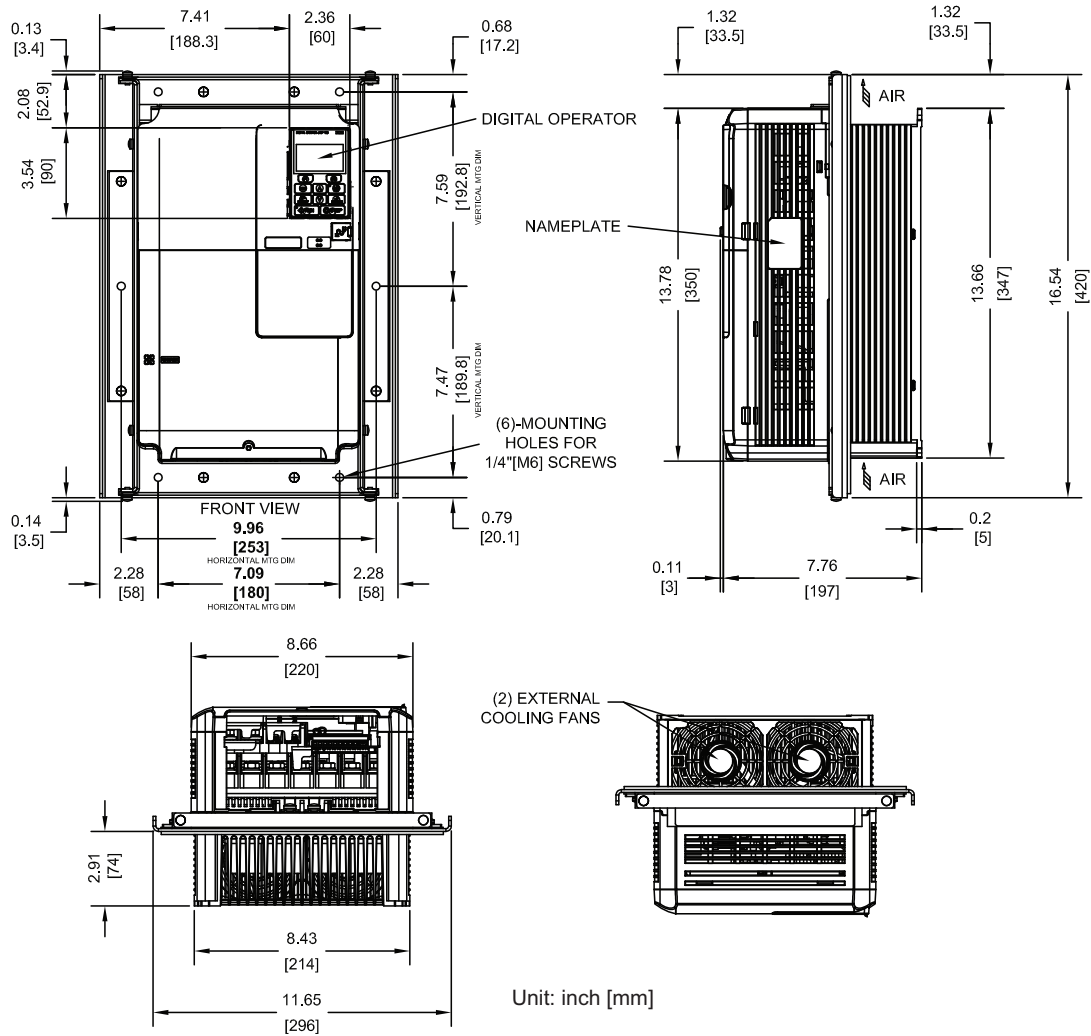

Figure 9 Dimensions (Models 2A0069U, 2A0081U, 4A0044U, 5A0027U, 5A0032U)

■ A1000 & P1000 Models 2A0110U, 4A0058U

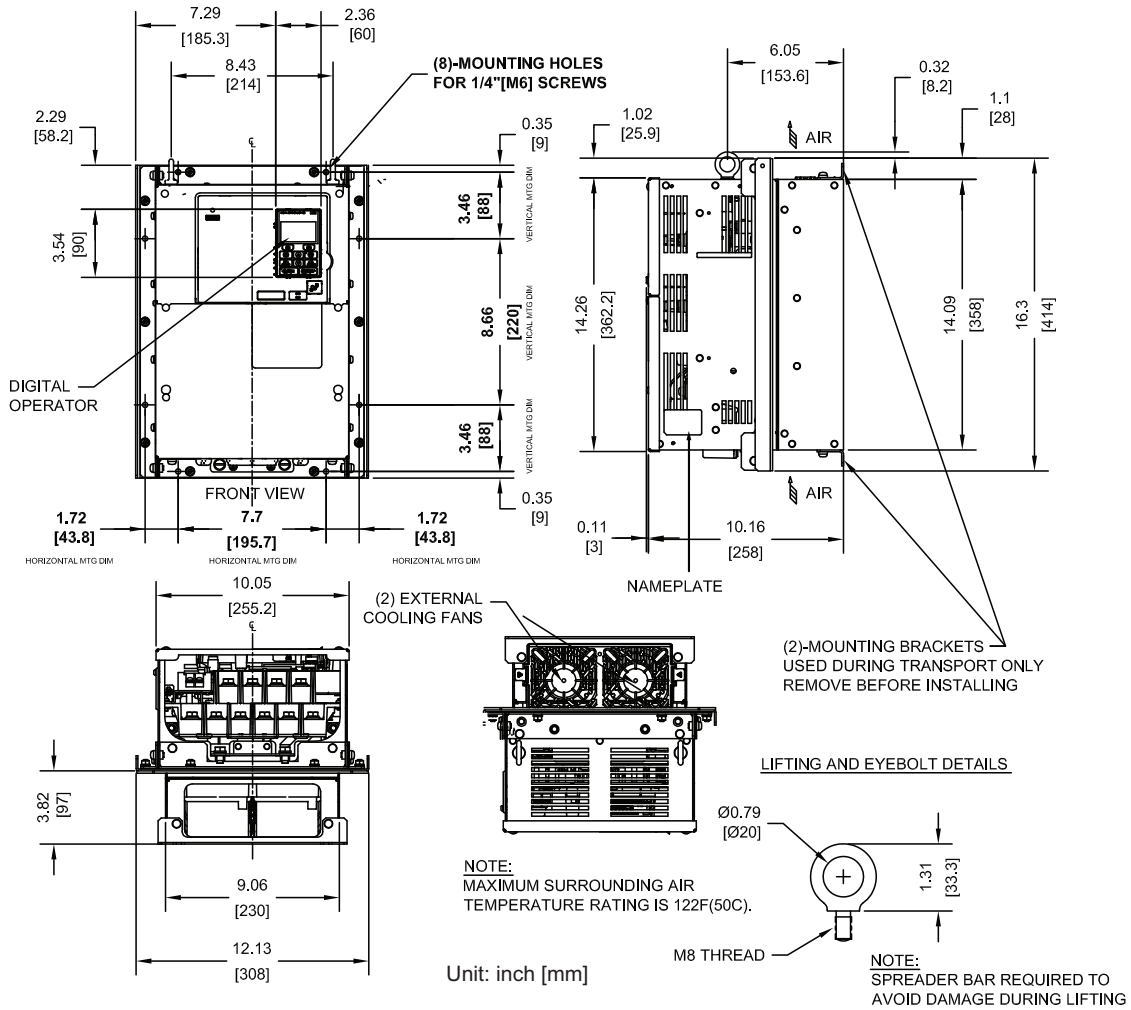

Figure 10 Dimensions (Models 2A0110U, 4A0058U)

6 Supplemental Information - Flange Type Enclosure

■ A1000 & P1000 Models 2A0138U, 4A0072U, 5A0041U, 5A0052U

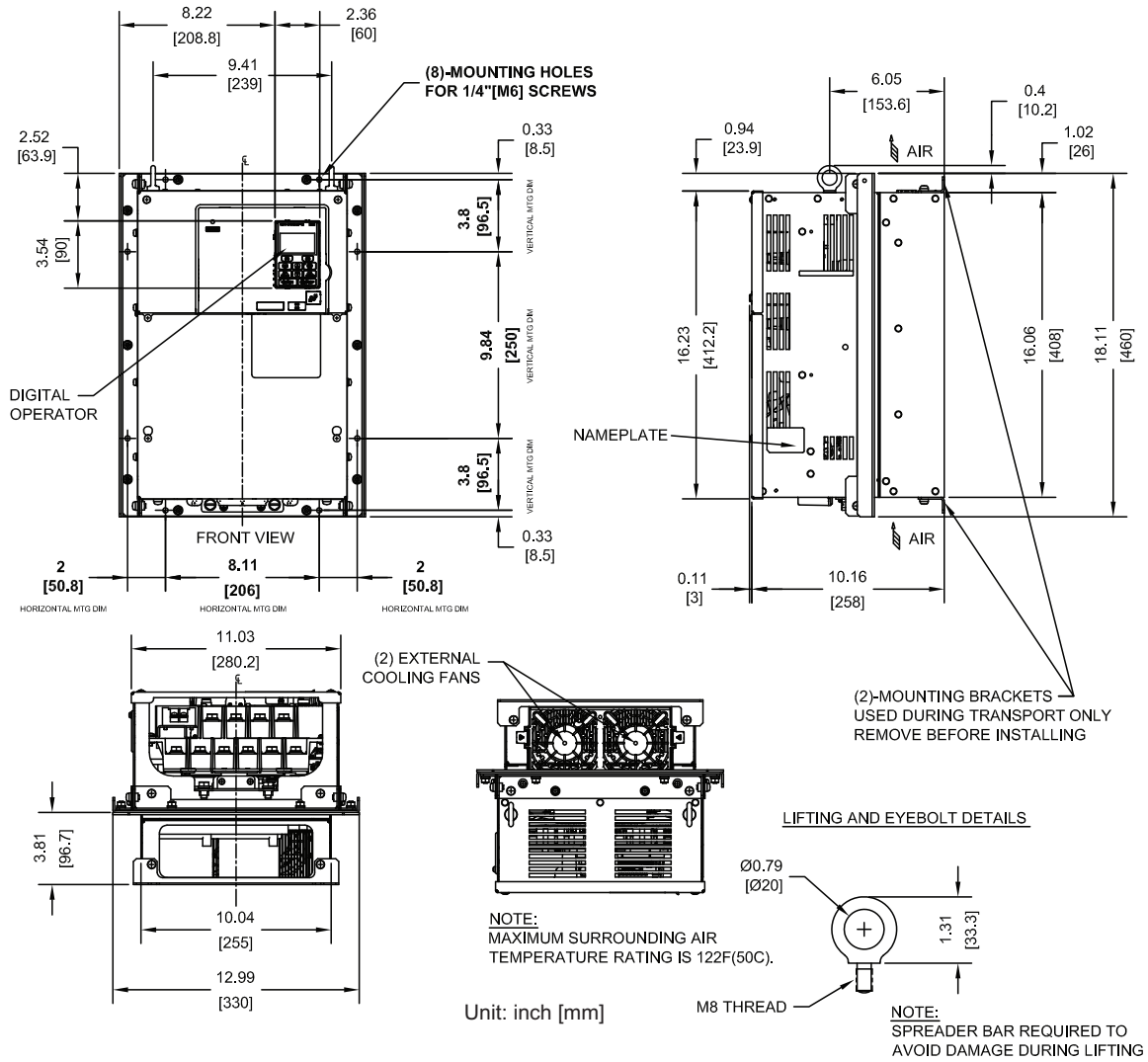

Figure 11 Dimensions (Models 2A0138U, 4A0072U, 5A0041U, 5A0052U)

■ A1000 & P1000 Models 4A0088U, 4A0103U

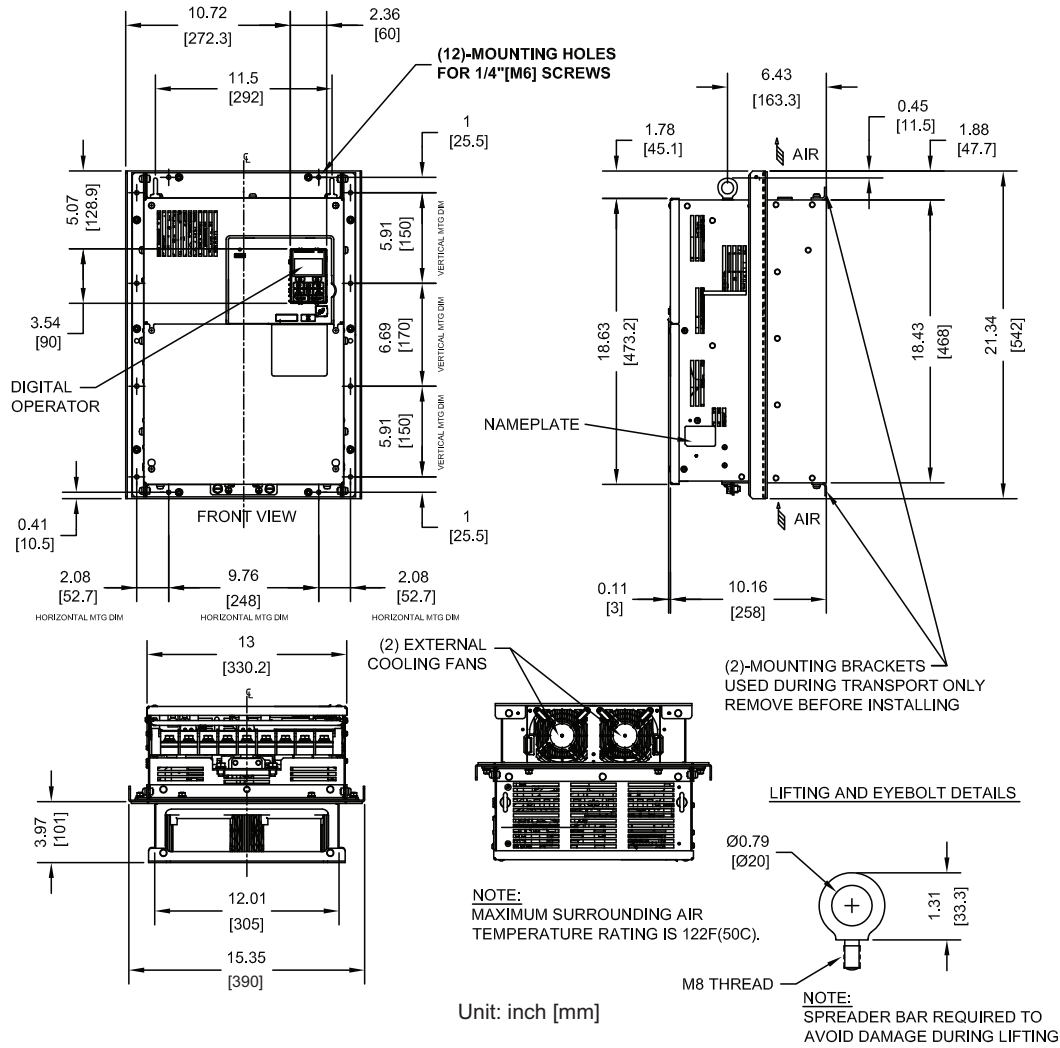

Figure 12 Dimensions (Models 4A0088U, 4A0103U)

6 Supplemental Information - Flange Type Enclosure

■ A1000 & P1000 Models 2A0169U to 0211U, 4A0139U to 0165U, 5A0062U to 0099U

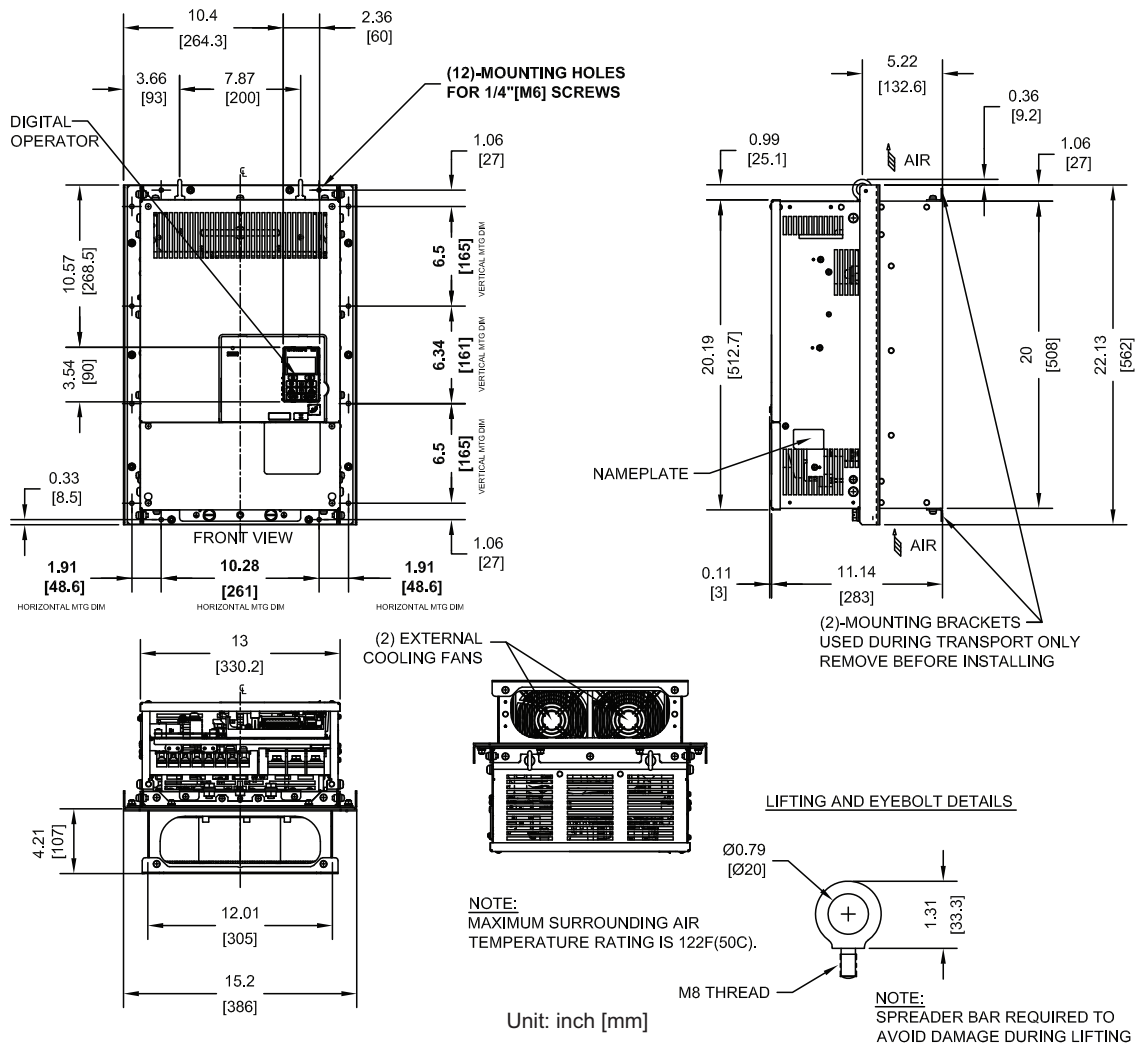

Figure 13 Dimensions (Models 2A0169U to 0211U, 4A0139U to 0165U, 5A0062U to 0099U)

■ A1000 & P1000 Models 2A0250U to 0312U, 4A0208U, 5A0125U to 0145U

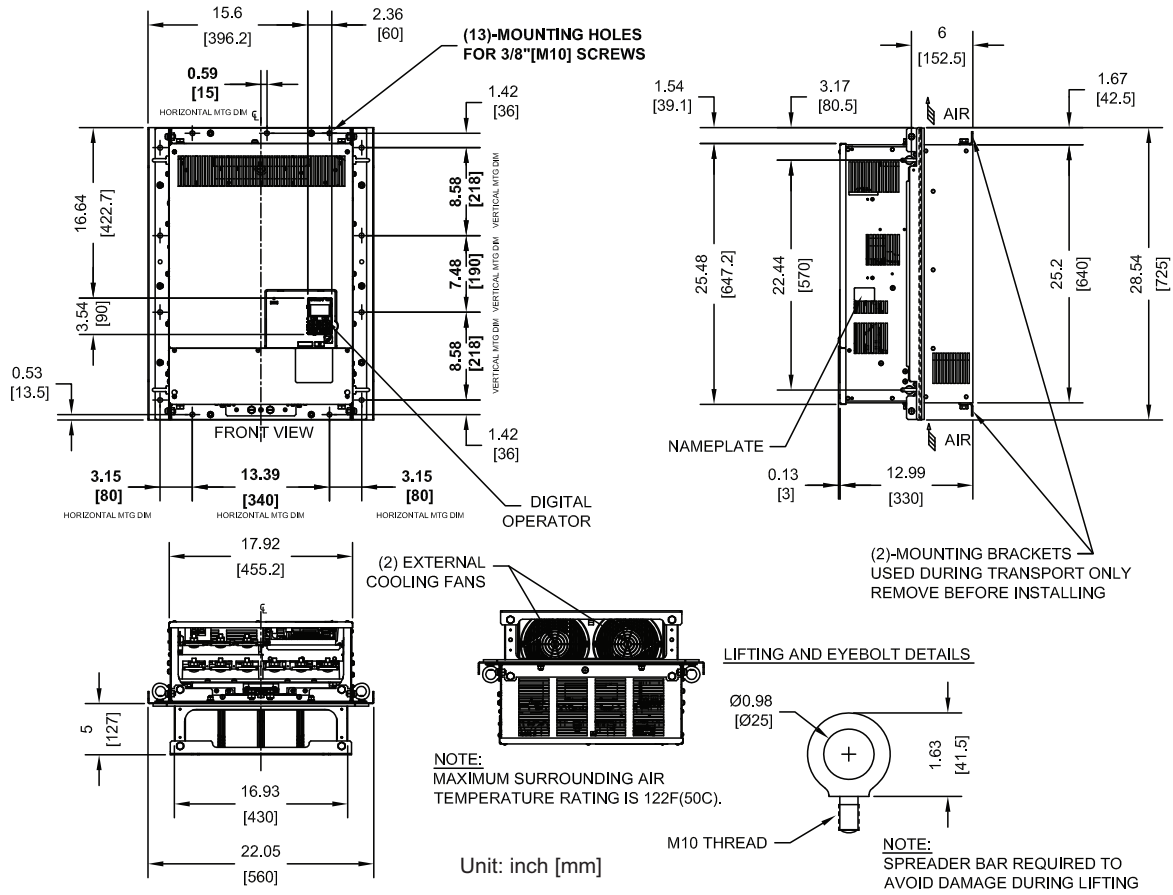

Figure 14 Dimensions (Models 2A0250U to 0312U, 4A0208U, 5A0125U to 0145U)

6 Supplemental Information - Flange Type Enclosure

■ A1000 & P1000 Models 2A0360U to 0415U, 4A0250U to 0362U, 5A0192U to 0242U

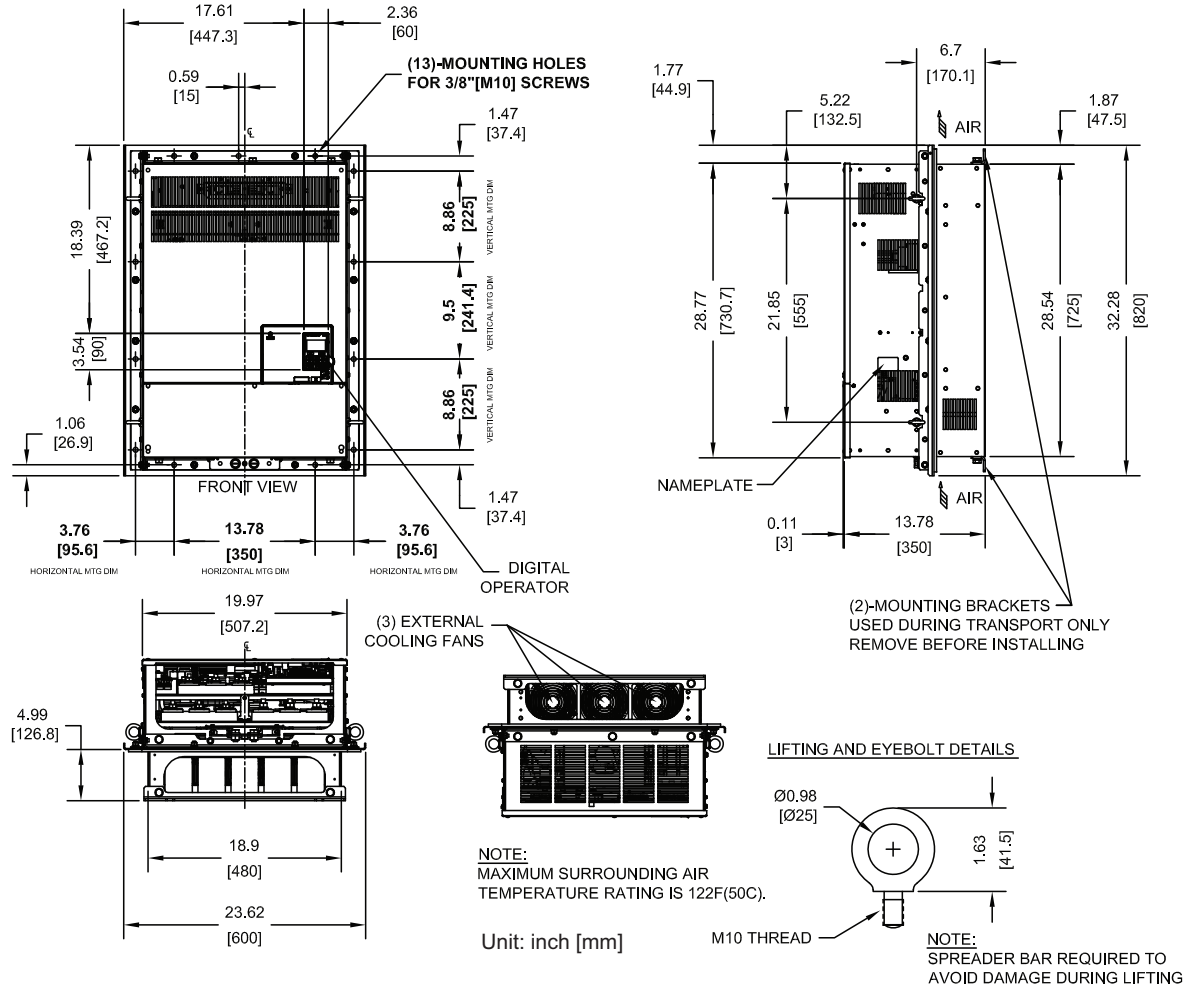

Figure 15 Dimensions (Models 2A0360U to 0415U, 4A0250U to 0362U, 5A0192U to 0242U)

■ A1000 & P1000 Model 4A0414U

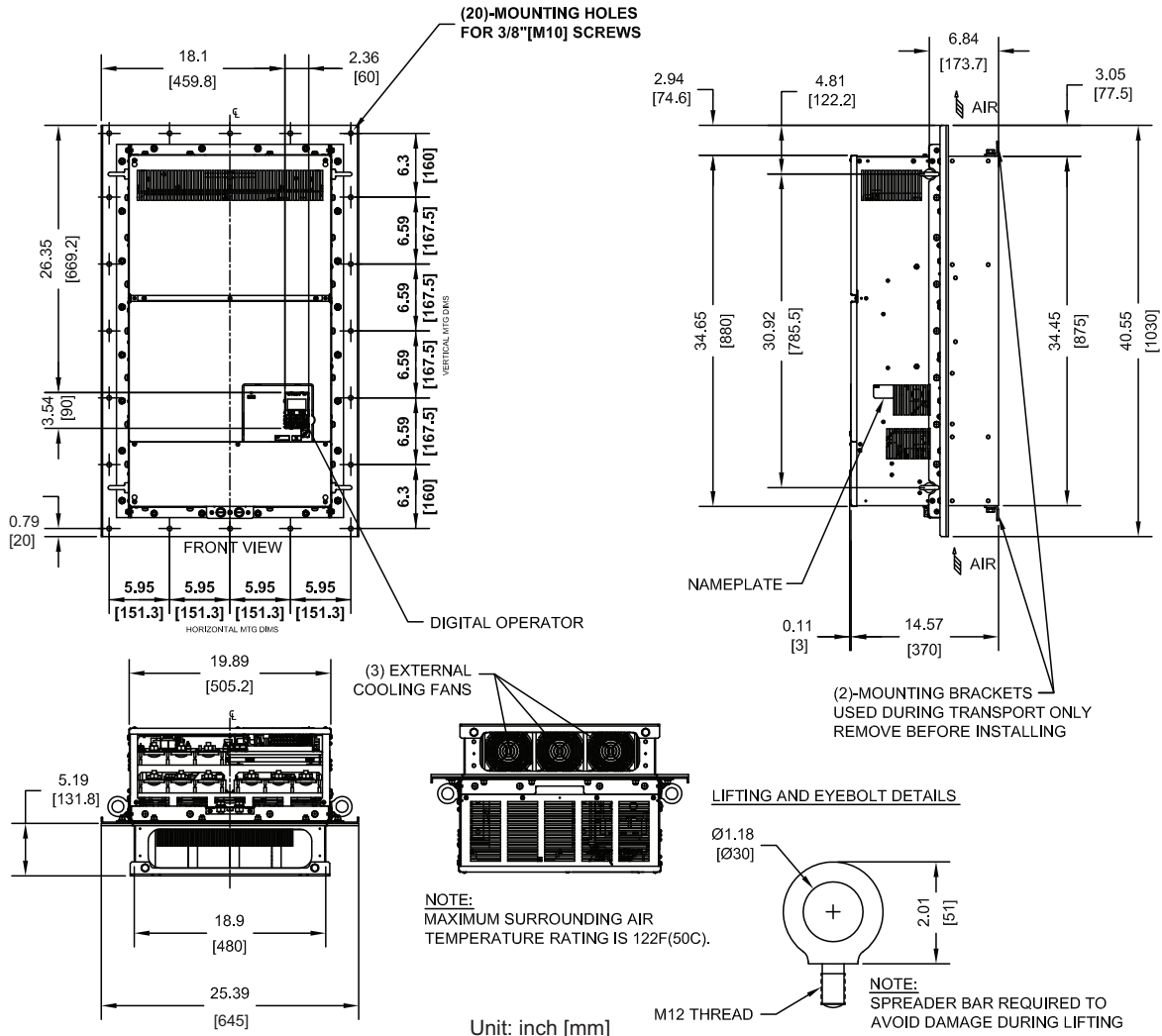

Figure 16 Dimensions (Model 4A0414U)

6 Supplemental Information - Flange Type Enclosure

■ A1000 & P1000 Models 4A0515U, 4A0675U

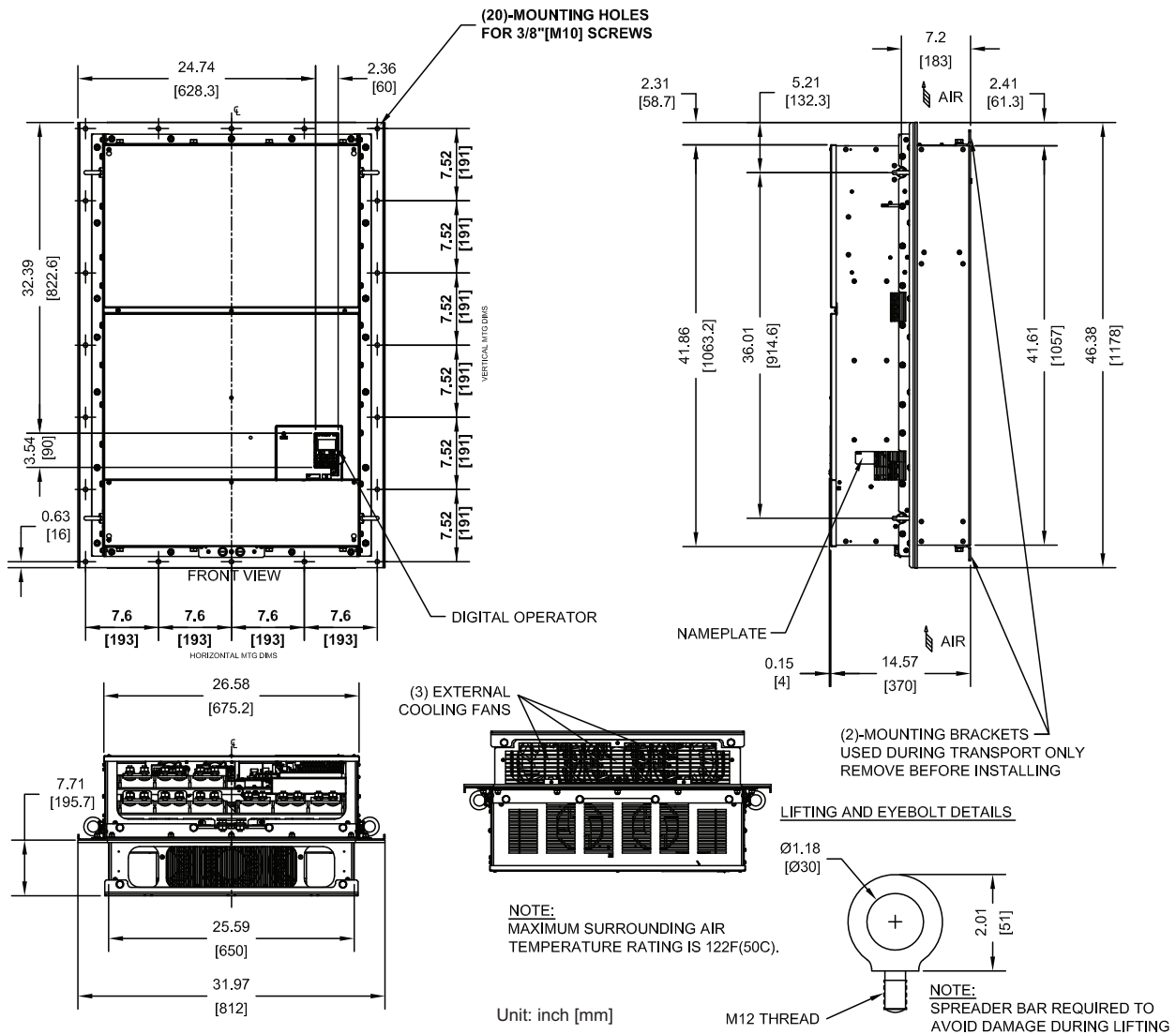
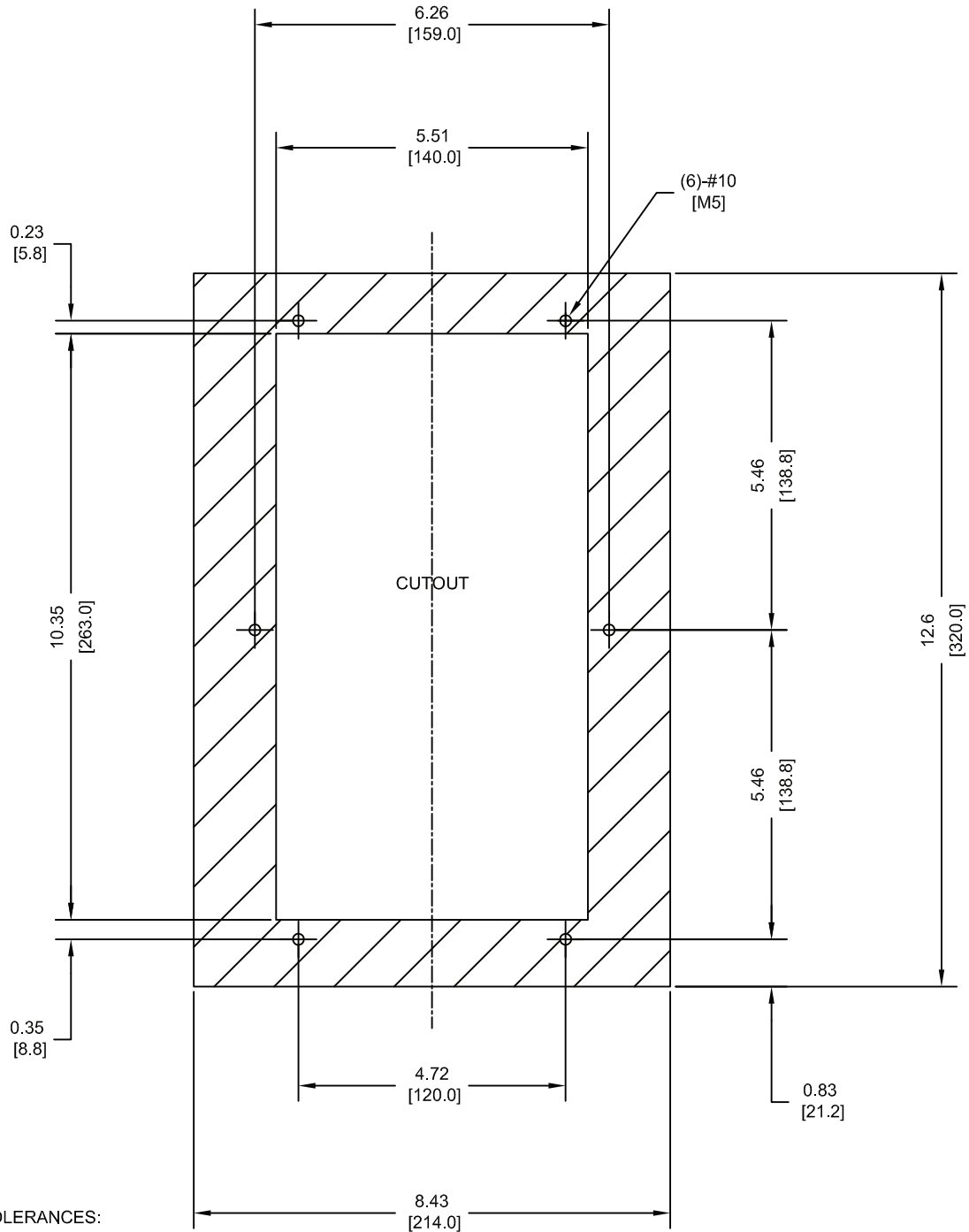

Figure 17 Dimensions (Models 4A0515U, 4A0675U)

◆ Panel Cut-Out Dimensions - Flange Type Enclosure (NEMA 12 Backside)

■ A1000 & P1000 Models 2A0004U to 0012U, 4A0002U to 0005U, 5A0003U to 0004U



NOTES:

1. CUTOUT TOLERANCES:
+/- 0.02IN (0.5MM)
2. EXPOSED HEATSINK
RECOMMENDED CLEARANCE
D=1.97" MINUS PANEL THICKNESS

Unit: inch [mm]

Figure 18 Panel Cut-Out Dimensions (Models 2A0004U to 0012U, 4A0002U to 0005U, 5A0003U to 0004U)

6 Supplemental Information - Flange Type Enclosure

■ A1000 & P1000 Models 2A0018U to 0021U, 4A0007U to 0011U, 5A0006U to 0009U

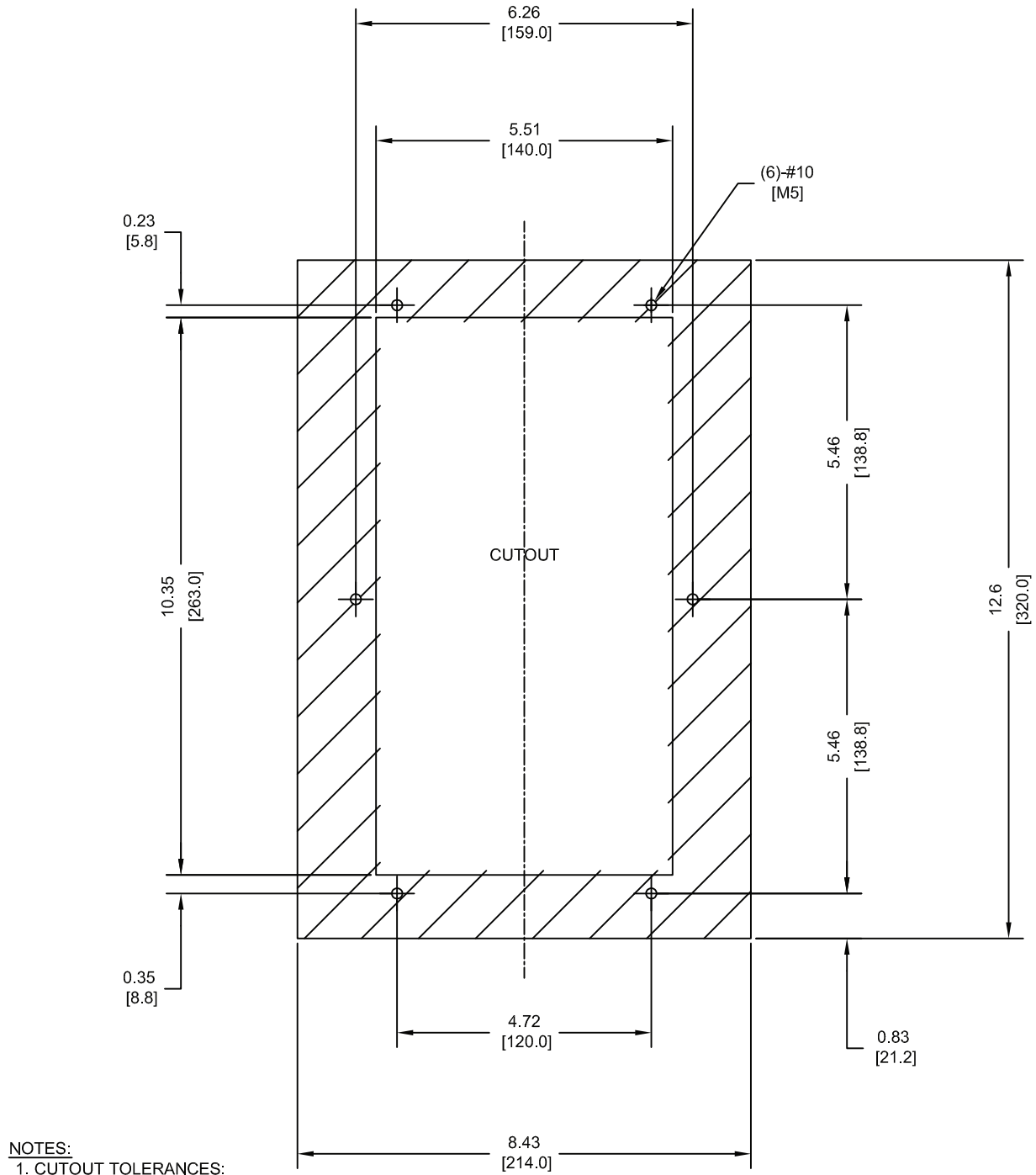

Unit: inch [mm]

Figure 19 Panel Cut-Out Dimensions (Models 2A0018U to 0021U, 4A0007U to 0011U, 5A0006U to 0009U)

■ A1000 & P1000 Models 2A0030U to 0040U, 4A0018U to 0023U, 5A0011U

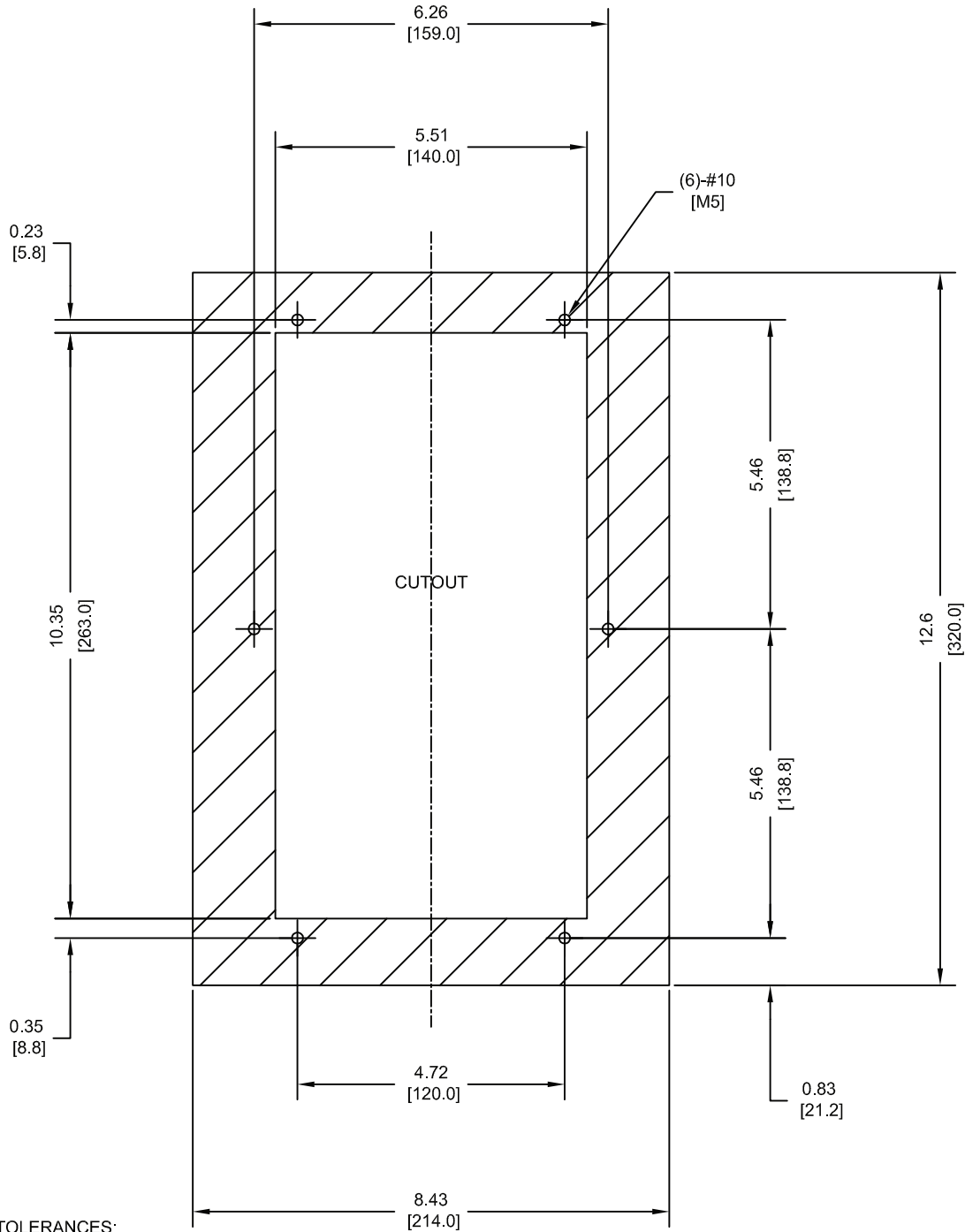

NOTES:

1. CUTOUT TOLERANCES:
+/- 0.02IN (0.5MM)
2. EXPOSED HEATSINK
RECOMMENDED CLEARANCE
D=2.36" MINUS PANEL THICKNESS

Unit: inch [mm]

Figure 20 Panel Cut-Out Dimensions (Models 2A0030U to 0040U, 4A0018U to 0023U, 5A0011U)

6 Supplemental Information - Flange Type Enclosure

■ A1000 & P1000 Model 4A0031U

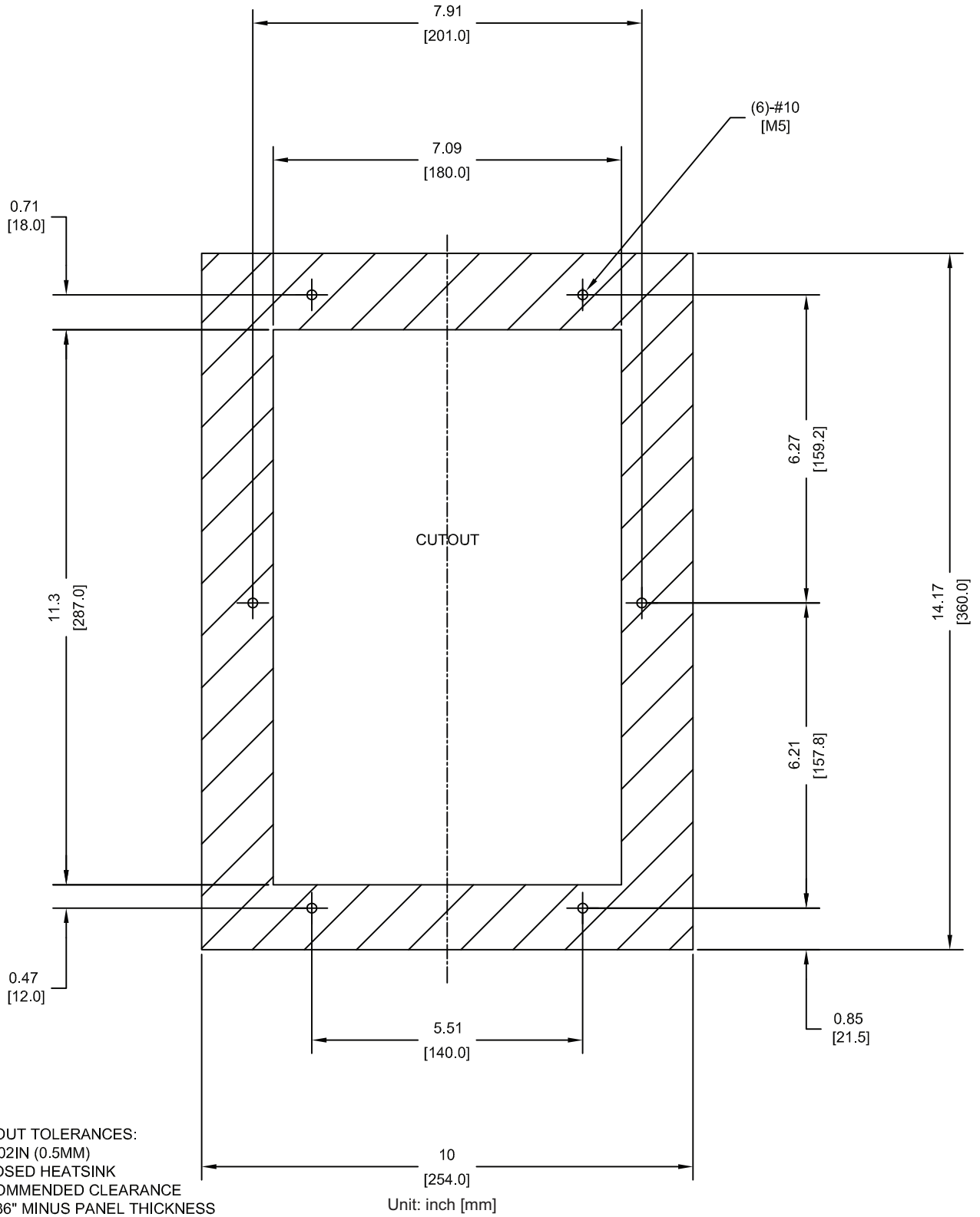

Figure 21 Panel Cut-Out Dimensions (Model 4A0031U)

■ A1000 & P1000 Models 2A0056U, 4A0038U, 5A0017U, 5A0022U

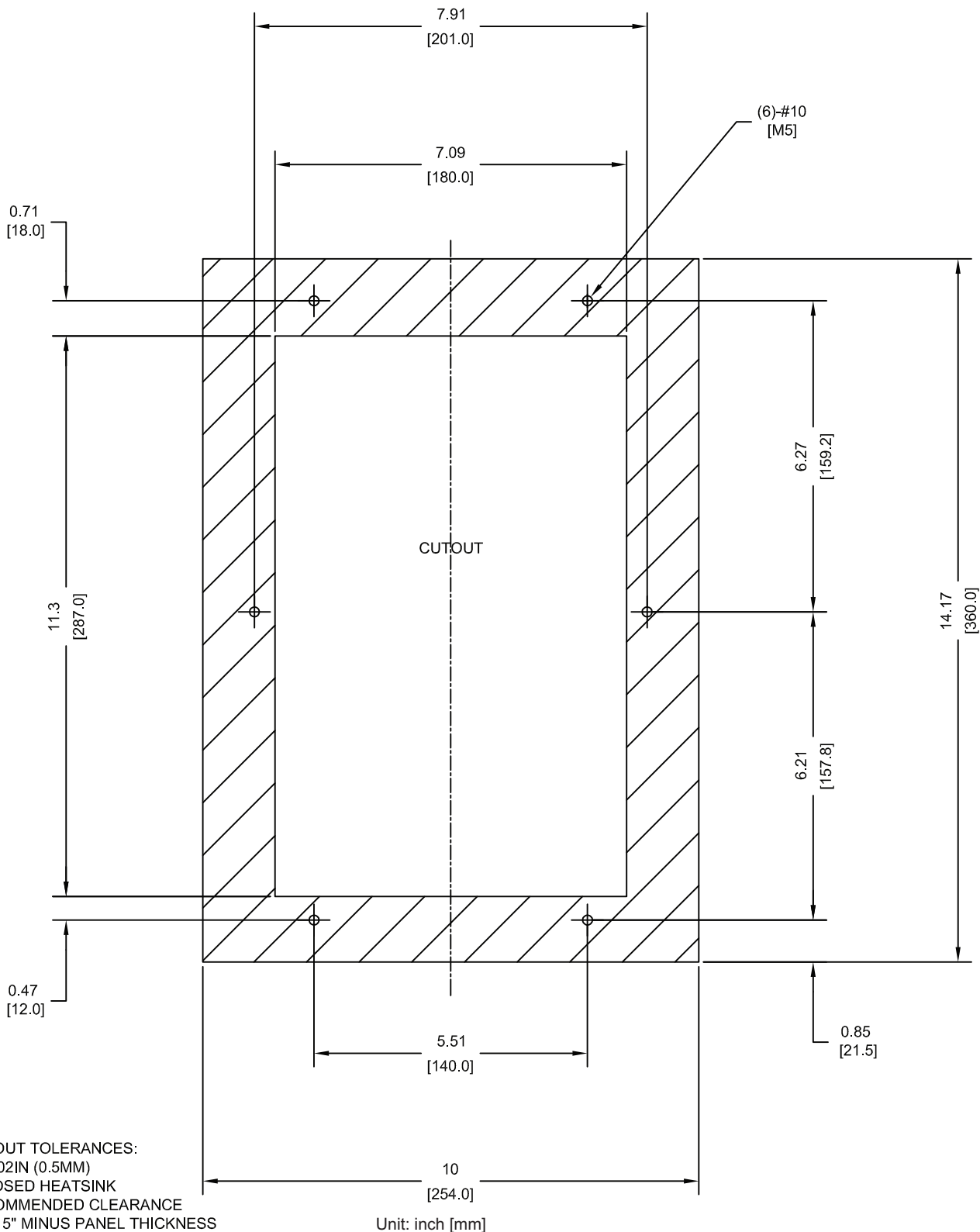

Figure 22 Panel Cut-Out Dimensions (Models 2A0056U, 4A0038U, 5A0017U, 5A0022U)

6 Supplemental Information - Flange Type Enclosure

■ A1000 & P1000 Models 2A0069U, 2A0081U, 4A0044U, 5A0027U, 5A0032U

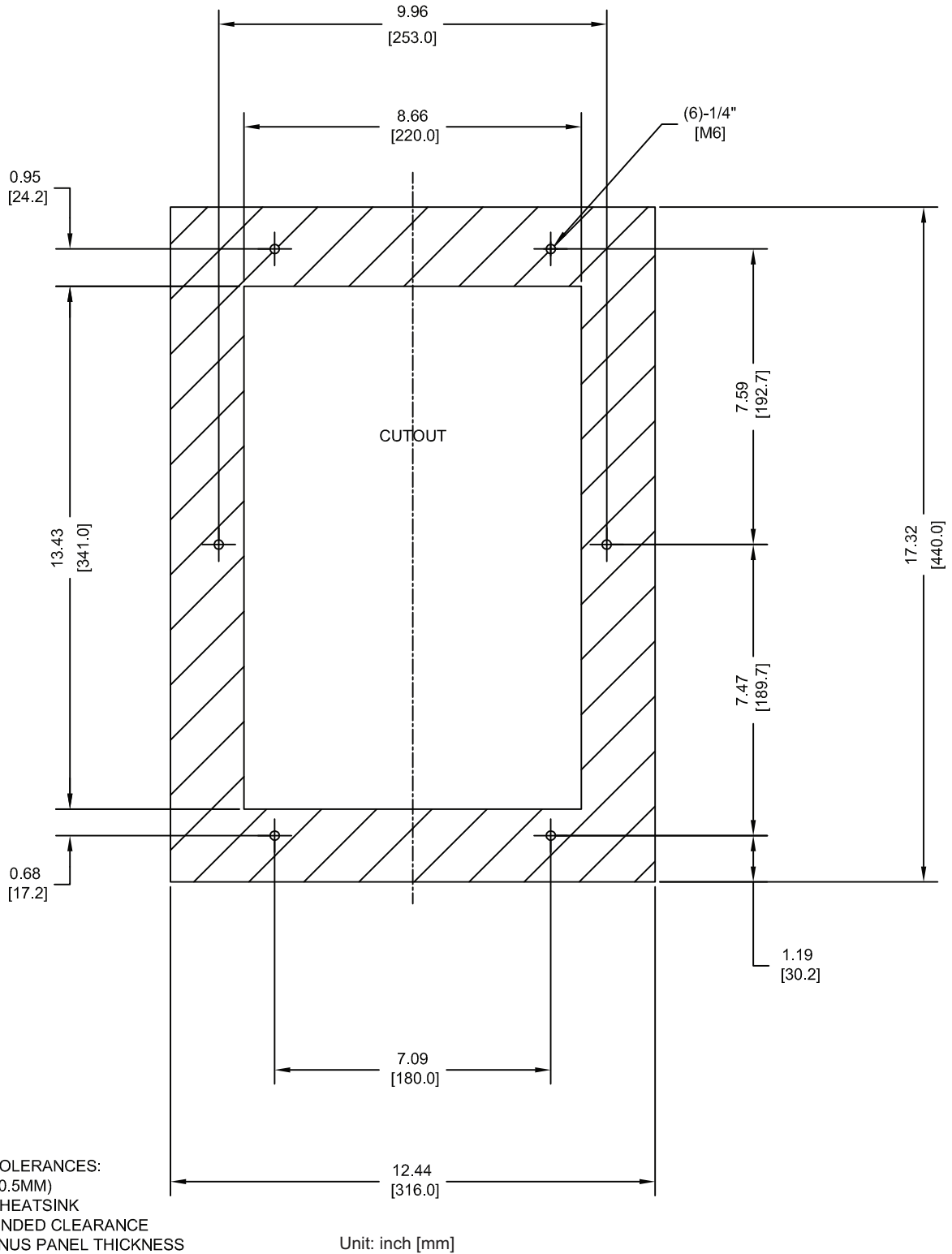

Figure 23 Panel Cut-Out Dimensions (Models 2A0069U, 2A0081U, 4A0044U, 5A0027U, 5A0032U)

■ A1000 & P1000 Models 2A0110U, 4A0058U

NOTES:

1. CUTOUT TOLERANCES:
+/- 0.02IN (0.5MM)
2. EXPOSED HEATSINK DEPTH
D=3.82" MINUS PANEL THICKNESS
3. MIN. RECOMMENDED PANEL
THICKNESS: 12 GA

Unit: inch [mm]

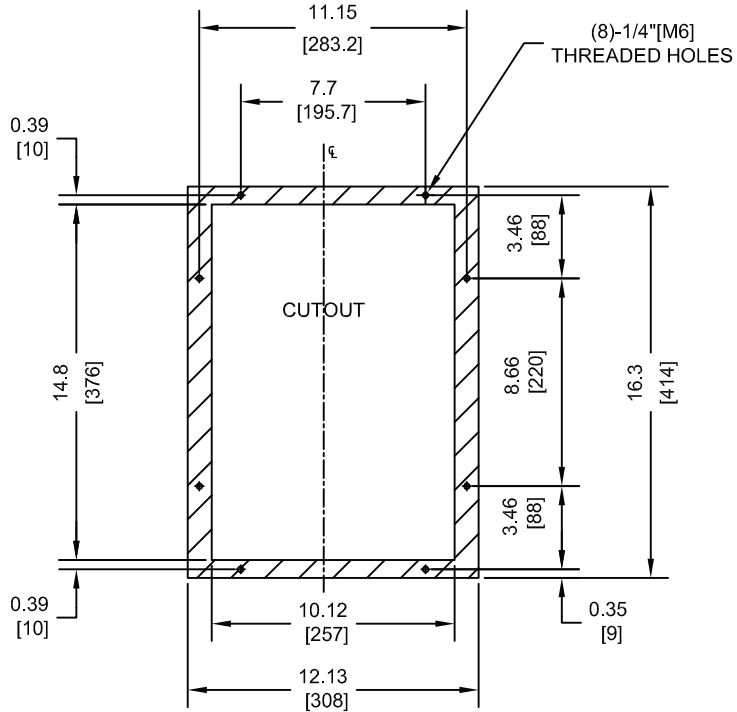

Figure 24 Panel Cut-Out Dimensions (Models 2A0110U, 4A0058U)

■ A1000 & P1000 Models 2A0138U, 4A0072U, 5A0041U, 5A0052U

NOTES:

1. CUTOUT TOLERANCES:
+/- 0.02IN (0.5MM)
2. EXPOSED HEATSINK DEPTH
D=3.81" MINUS PANEL THICKNESS
3. MIN. RECOMMENDED PANEL
THICKNESS: 12 GA

Unit: inch [mm]

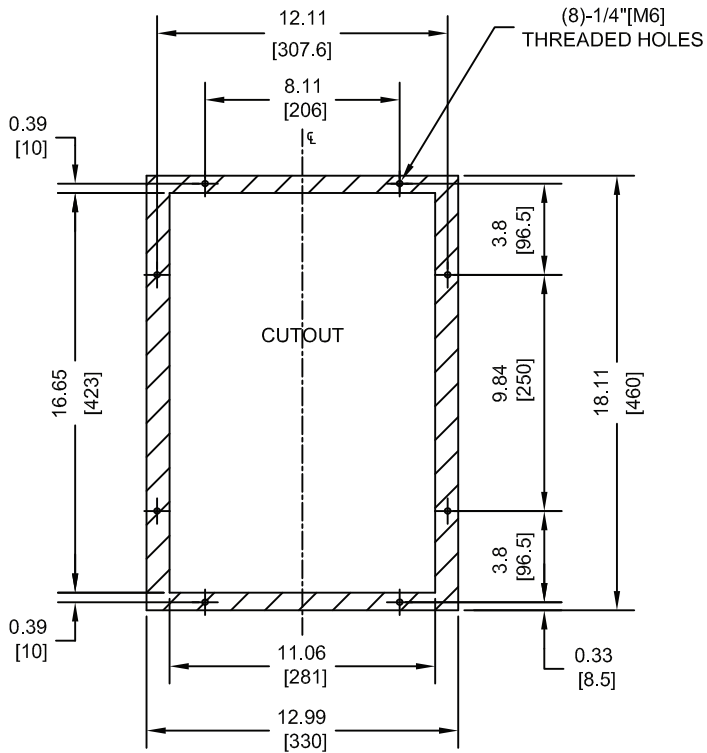

Figure 25 Panel Cut-Out Dimensions (Models 2A0138U, 4A0072U, 5A0041U, 5A0052U)

6 Supplemental Information - Flange Type Enclosure

■ A1000 & P1000 Models 4A0088U, 4A0103U

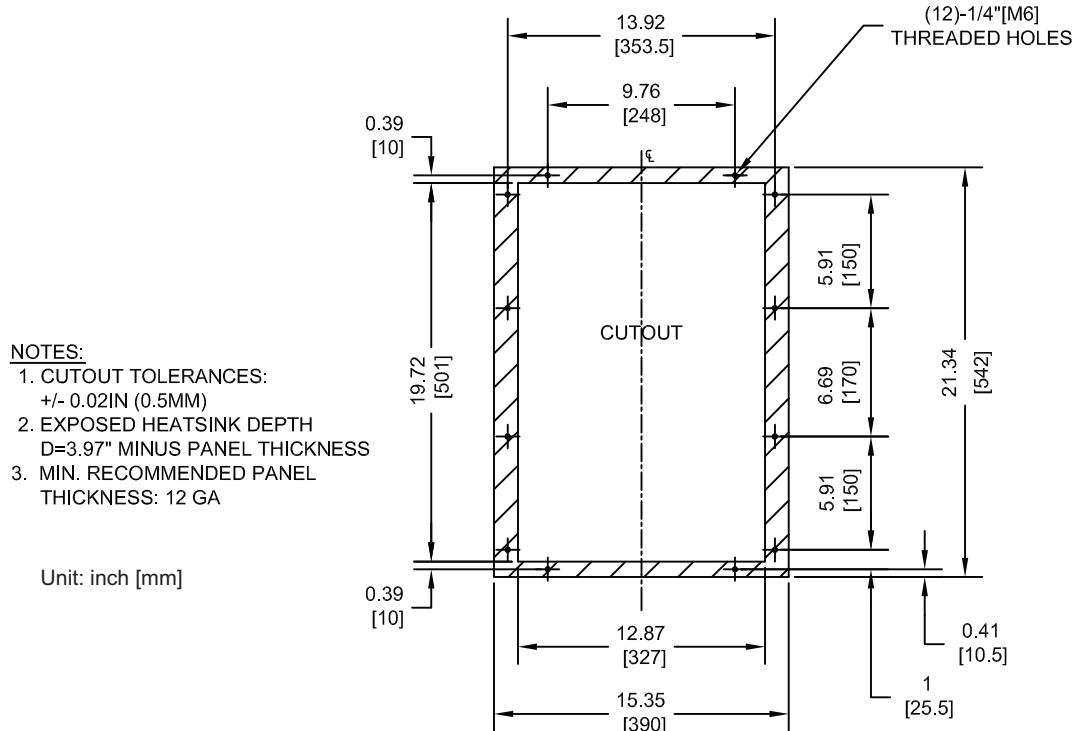

Figure 26 Panel Cut-Out Dimensions (Models 4A0088U, 4A0103U)

■ Models 2A0169U to 0211U, 4A0139U to 0165U, 5A0062U to 0099U

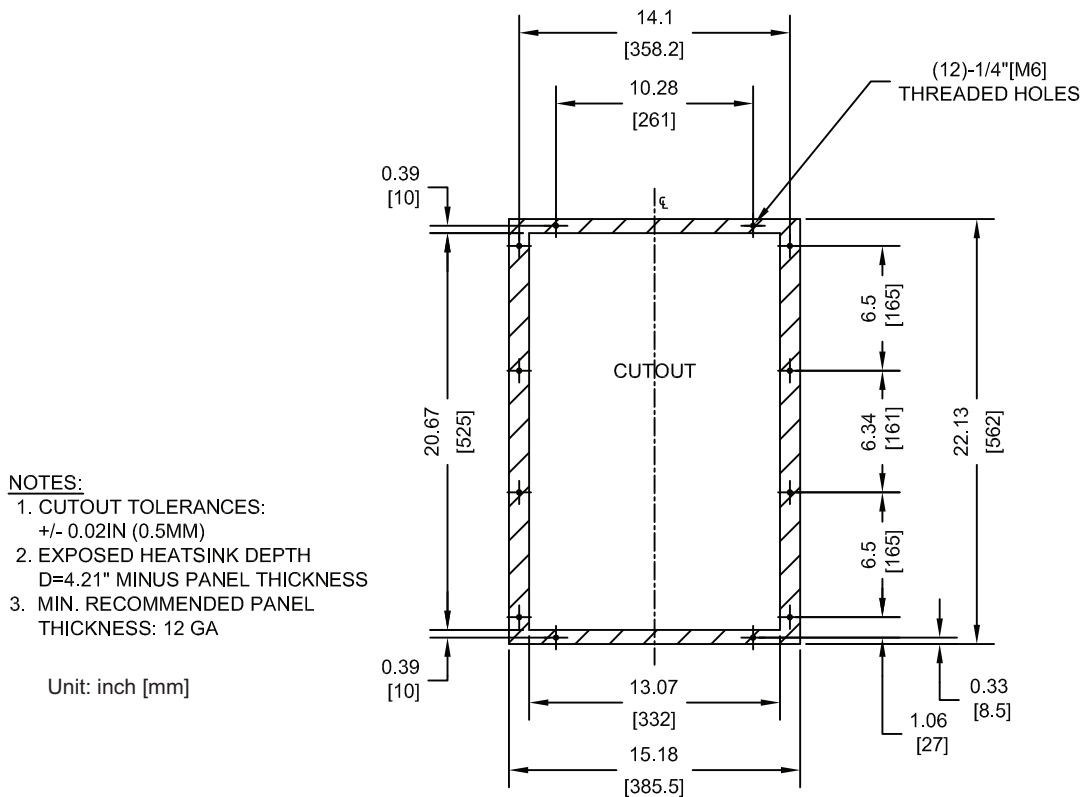

Figure 27 Panel Cut-Out Dimensions (Models 2A0169U to 0211U, 4A0139U to 0165U, 5A0062U to 0099U)

■ A1000 & P1000 Models 2A0250U to 0312U, 4A0208U, 5A0125U to 0145U

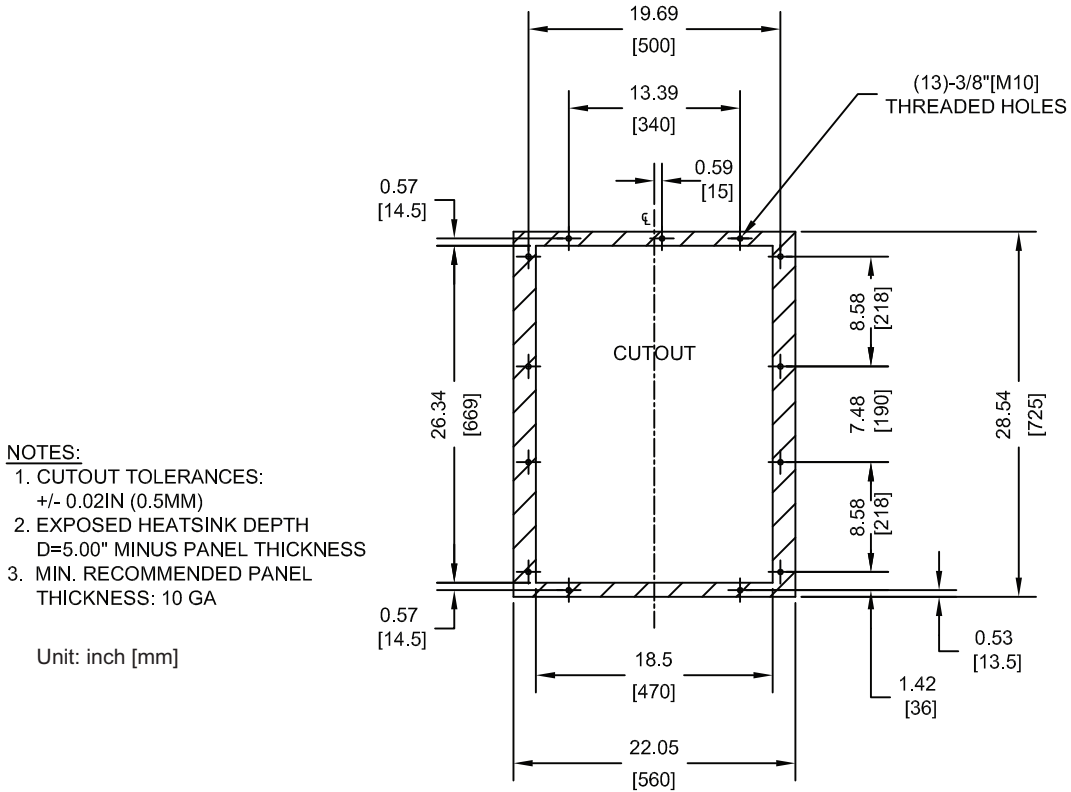

Figure 28 Panel Cut-Out Dimensions (Models 2A0250U to 0312U, 4A0208U, 5A0125U to 0145U)

■ A1000 & P1000 Models 2A0360U to 0415U, 4A0250U to 0362U, 5A0192U to 0242U

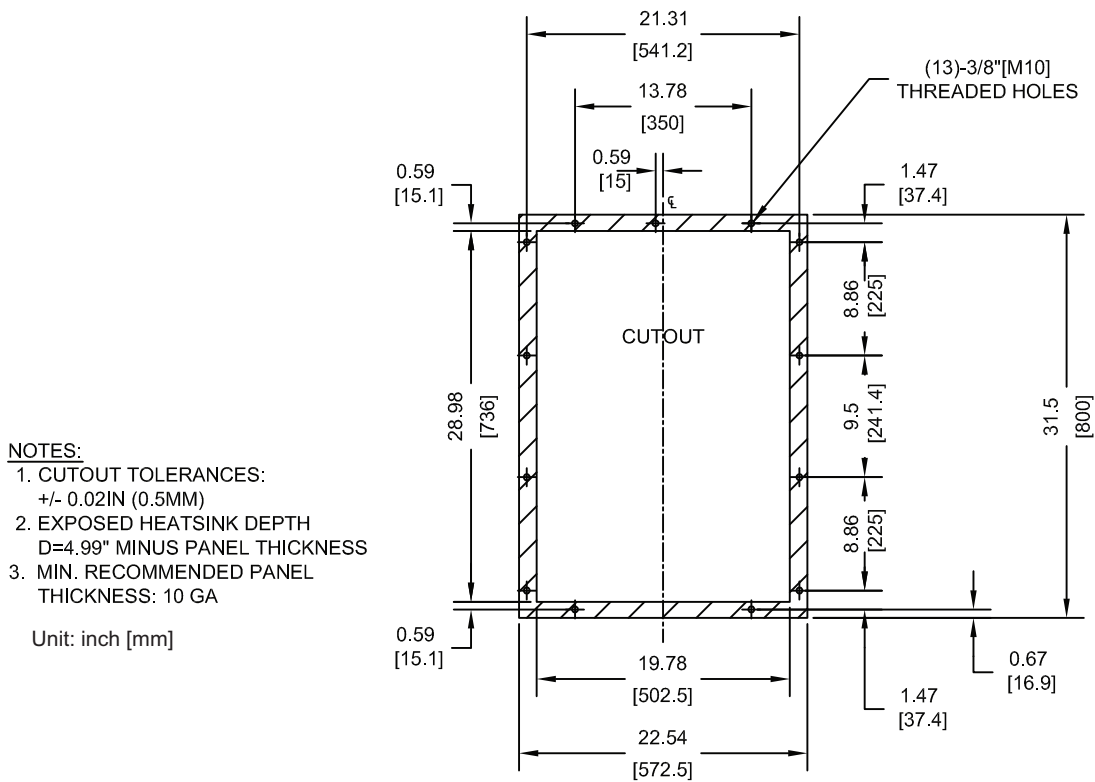

Figure 29 Panel Cut-Out Dimensions (Models 2A0360U to 0415U, 4A0250U to 0362U, 5A0192U to 0242U)

6 Supplemental Information - Flange Type Enclosure

■ A1000 & P1000 Model 4A0414U

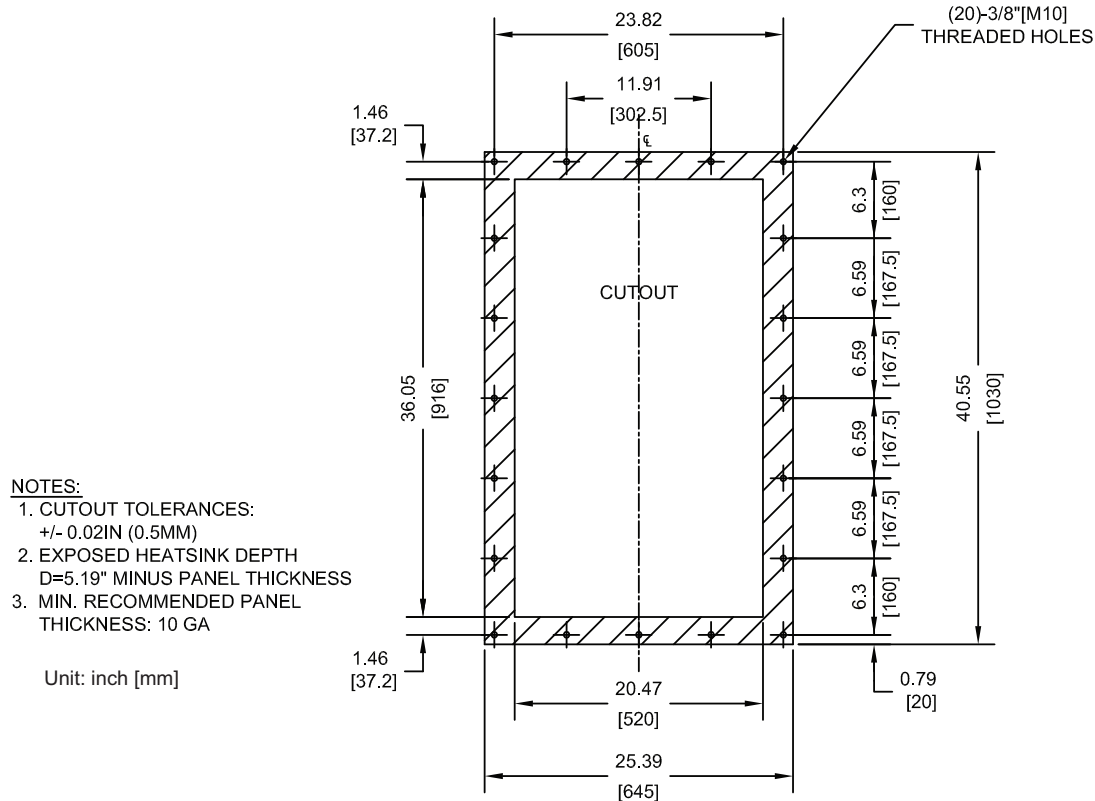

Figure 30 Panel Cut-Out Dimensions (Model 4A0414U)

■ A1000 & P1000 Models 4A0515U, 4A0675U

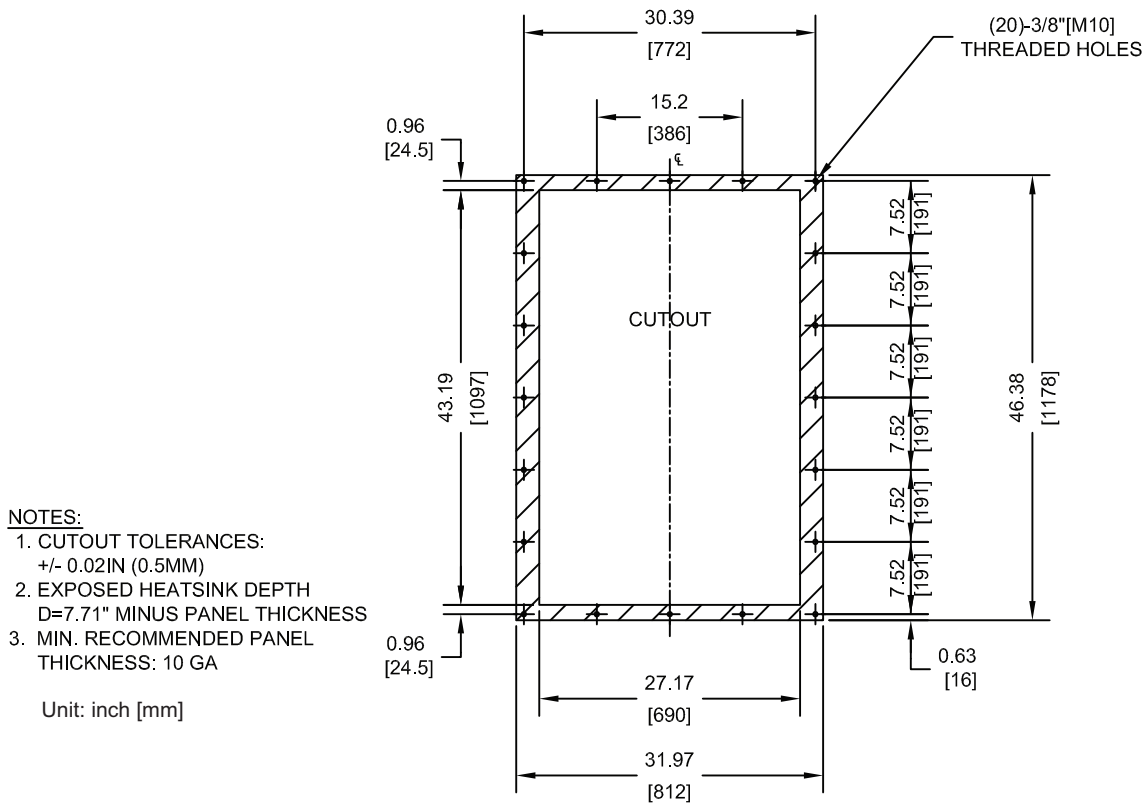

Figure 31 Panel Cut-Out Dimensions (Models 4A0515U, 4A0675U)

◆ Weight - A1000 & P1000 Flange Type Enclosure (NEMA 12 Backside)

Table 10 Drive Weight by Model - 200 V Class

Model 2A□□□□U	0004	0006	0008	0010	0012	0018	0021	0030	0040	0056	0069	0081	0110
Drive Weight lb (kg)	7.3 (3.3)	7.3 (3.3)	7.5 (3.4)	7.5 (3.4)	7.5 (3.4)	8.1 (3.7)	8.1 (3.7)	9.2 (4.2)	9.2 (4.2)	13.0 (5.9)	20.0 (9.1)	22.0 (10.0)	50.6 (23.0)
	0138	0169	0211	0250	0312	0360	0415	-	-	-	-	-	-
	61.6 (28.0)	90.2 (41.0)	92.4 (42.0)	183 (83)	194 (88)	238 (108)	-	-	-	-	-	-	-

Table 11 Drive Weight by Model - 400 V Class

Model 4A□□□□U	0002	0004	0005	0007	0009	0011	0018	0023	0031	0038	0044	0058	0072
Drive Weight lb (kg)	7.5 (3.4)	7.5 (3.4)	7.5 (3.4)	7.9 (3.6)	8.1 (3.7)	8.1 (3.7)	9.0 (4.1)	9.0 (4.1)	12.5 (5.7)	13.2 (6.0)	19.1 (8.7)	50.6 (23.0)	59.4 (27.0)
	0088	0103	0139	0165	0208	0250	0296	0362	0414	0515	0675	-	-
	85.8 (39.0)	85.8 (39.0)	99.0 (45.0)	101.2 (46.0)	191 (87)	233 (106)	246 (112)	257 (117)	-	-	-	-	-

Table 12 Drive Weight by Model - 600 V Class

Model 5A□□□□U	0003	0004	0006	0009	0011	0017	0022	0027	0032	0041	0052	0062	0077
Drive Weight lb (kg)	7.5 (3.4)	7.5 (3.4)	8.1 (3.7)	8.1 (3.7)	9.0 (4.1)	13.2 (6.0)	13.2 (6.0)	19.1 (8.7)	19.1 (8.7)	59.4 (27.0)	59.4 (27.0)	99.0 (45.0)	99.0 (45.0)
	0099	0125	0145	0192	0242	-	-	-	-	-	-	-	-
	99.0 (45.0)	191 (87)	191 (87)	257 (117)	257 (117)	-	-	-	-	-	-	-	-

■ Notes:

YASKAWA AC Drive - A1000 and P1000

Manual Supplement

Supplement to: A1000 Quick Start Guide TOEP C710616 41

Supplement to: P1000 Quick Start Guide TOEP YAIP1U 01

YASKAWA AMERICA, INC.

2121 Norman Drive South, Waukegan, IL 60085, U.S.A.
Phone: (800) YASKAWA (927-5292) or 1-847-887-7000 Fax: 1-847-887-7310
<http://www.yaskawa.com>

DRIVE CENTER (INVERTER PLANT)

2-13-1, Nishimiyaichi, Yukuhashi, Fukuoka, 824-8511, Japan
Phone: 81-930-25-3844 Fax: 81-930-25-4369
<http://www.yaskawa.co.jp>

YASKAWA ELECTRIC CORPORATION

New Pier Takeshiba South Tower, 1-16-1, Kaigan, Minatoku, Tokyo, 105-6891, Japan
Phone: 81-3-5402-4502 Fax: 81-3-5402-4580
<http://www.yaskawa.co.jp>

YASKAWA ELÉTRICO DO BRASIL LTDA.

Avenda Fagundes Filho, 620 Bairro Saude, São Paulo, SP04304-000, Brasil
Phone: 55-11-3585-1100 Fax: 55-11-5581-8795
<http://www.yaskawa.com.br>

YASKAWA EUROPE GmbH

Hauptstrasse 185, 65760 Eschborn, Germany
Phone: 49-6196-569-300 Fax: 49-6196-569-398
<http://www.yaskawa.eu.com>

YASKAWA ELECTRIC UK LTD.

1 Hunt Hill Orchardton Woods, Cumbernauld, G68 9LF, United Kingdom
Phone: 44-1236-735000 Fax: 44-1236-458182
<http://www.yaskawa.co.uk>

YASKAWA ELECTRIC KOREA CORPORATION

7F, Doore Bldg. 24, Yeoido-dong, Yeongdungpo-gu, Seoul, 150-877, Korea
Phone: 82-2-784-7844 Fax: 82-2-784-8495
<http://www.yaskawa.co.kr>

YASKAWA ELECTRIC (SINGAPORE) PTE. LTD.

151 Lorong Chuan, #04-01, New Tech Park, 556741, Singapore
Phone: 65-6282-3003 Fax: 65-6289-3003
<http://www.yaskawa.com.sg>

YASKAWA ELECTRIC (SHANGHAI) CO., LTD.

No. 18 Xizang Zhong Road, 17F, Harbour Ring Plaza, Shanghai, 200001, China
Phone: 86-21-5385-2200 Fax: 86-21-5385-3299
<http://www.yaskawa.com.cn>

YASKAWA ELECTRIC (SHANGHAI) CO., LTD. BEIJING OFFICE

Room 1011, Tower W3 Oriental Plaza, No. 1 East Chang An Ave.,
Dong Cheng District, Beijing, 100738, China
Phone: 86-10-8518-4086 Fax: 86-10-8518-4082

YASKAWA ELECTRIC TAIWAN CORPORATION

9F, 16, Nanking E. Rd., Sec. 3, Taipei, 104, Taiwan
Phone: 886-2-2502-5003 Fax: 886-2-2505-1280



YASKAWA AMERICA, INC.

In the event that the end user of this product is to be the military and said product is to be employed in any weapons systems or the manufacture thereof, the export will fall under the relevant regulations as stipulated in the Foreign Exchange and Foreign Trade Regulations. Therefore, be sure to follow all procedures and submit all relevant documentation according to any and all rules, regulations and laws that may apply.

Specifications are subject to change without notice for ongoing product modifications and improvements.

© 2011 YASKAWA AMERICA, INC. All rights reserved.



MANUAL NO. TOEP YEASUP 03B <4>

Published in U.S.A. September 2012